

# ALB Checker

## Function Test

### NOTE:

- The ALB checker is designed to confirm proper operation of the ALB system by simulating each system function and operating condition. Before using the checker, confirm that the dash [ALB] warning light is not indicating some other problem with the system. The light should go on when the ignition is first turned on and then go off and stay off two seconds after the engine.
- The checker should be used through all modes, 1 to 6, to confirm proper operation of the system, in any one of the following situations:
  - After replacing any ALB system component.
  - After replacing or bleeding the system fluid.
  - After any body or suspension repair that may have affected the sensors or their wiring.
  - As art of P.D.I.

**⚠ WARNING** Be sure to disconnect the 4w A.L.B checker before driving the vehicle. If you drive the vehicle with the checker left connected, the ALB may operate when it is not otherwise supposed to.

1. With the ignition switch off, disconnect the 6-P inspection connector (PNK) from the connector cover on the floor of the under the driver's seat. Connect the 6-P inspection connector to the ALB checker and adaptor.

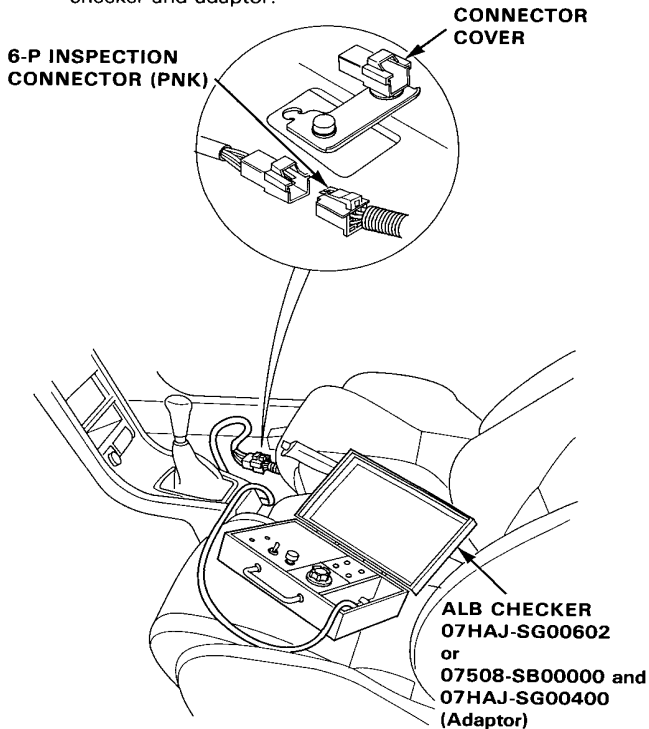

NOTE: The adaptor 07HAJ-SG00400 is not necessary when using of the checker 07HAJ-SG00602.

NOTE: Place the vehicle on level ground with the wheels blocked, put the transmission in neutral for manual transmission models, and in P for Automatic transmission models.

2. Start the engine and release the parking brake.
3. Operate the ALB checker as follows,
  - (1) For ALB checker 07508-SB00000, turn the power switch ON.  
For ALB checker 07HAJ-SG00602, select the pulse switch to "50 pulse" side.
  - (2) Turn the Mode Selector switch to "1."
  - (3) Push the Start Test switch:
    - The Busy light should come ON.
    - The dash [ALB] warning light should not come ON (if it comes on, follow the troubleshooting on page 13-14)

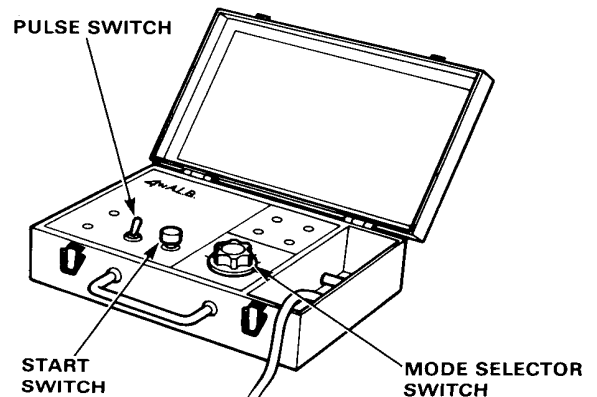

4. Turn the Mode Selector Switch further to "2".

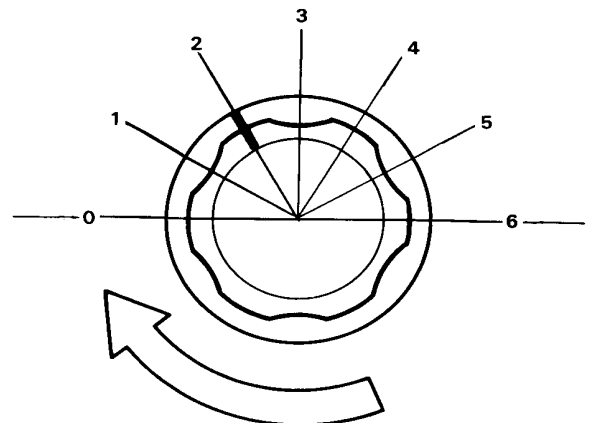

5. Depress the brake pedal and push the Start Test switch.  
The dash ALB warning light should not go on while the Busy light is ON. There should be kickback on the brake pedal. If not as described, go to troubleshooting, page 13-11.

NOTE: The operation sequence simulated by Modes 2, 3, 4, 5 and 6.

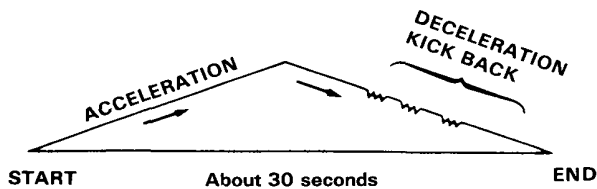

6. Turn the Mode Selector switch to 3, 4 and 5.  
Perform step 5 for each of the test mode positions.

**Mode 1:**

Sends the simulated driving signal 0 km/h (0mph) → 180km/h (112.5mph) → 0km/h (0 mph) of each wheel to the control unit to check the control unit self diagnosis circuit. There should be no kickback.

**Mode 2:**

Sends the driving signal of each wheel, then sends the lock signal of the rear left wheel to the control unit. There should be kickback.

**Mode 3:**

Sends the driving signal of each wheel, then sends the lock signal of the rear right wheel to the control unit. There should be kickback.

**Mode 4:**

Sends the driving signal of each wheel, then sends the lock signal of the front left wheel to the control unit. There should be kickback.

**Mode 5:**

Sends the driving signal of each wheel, then sends the lock signal of the front right wheel to the control unit. There should be kickback.

NOTE: If little or no kickback is felt from the brake pedal in modes 2-5, repeat the function test of modes 1-5 several times before beginning to troubleshoot other parts of the system.

**Inspection points:**

1. The **[ALB]** warning light goes ON in mode 1.
  - Check the wiring. If there is good condition, the control unit is faulty.
  - If **[ALB]** warning light goes on 120 seconds later but the power unit stops, refer to page 13-14.
2. There are no kickback in modes 2 through 5.
  - Faulty pressure switch (remains ON)
  - Shorted wires
  - Faulty or disconnected power unit coupler
  - Faulty power unit relay
3. Weak kickback in modes 2 through 5.
  - Bleed high pressure circuits.
4. Power unit stops in mode 1 but it does not stop and there are no kickback in modes 2 through 5.
  - Brake fluid leakage
  - Bleed power unit
  - Clogged power unit outlet
  - Clogged or deteriorated power unit hose