

Ground Distribution

Circuit Identification

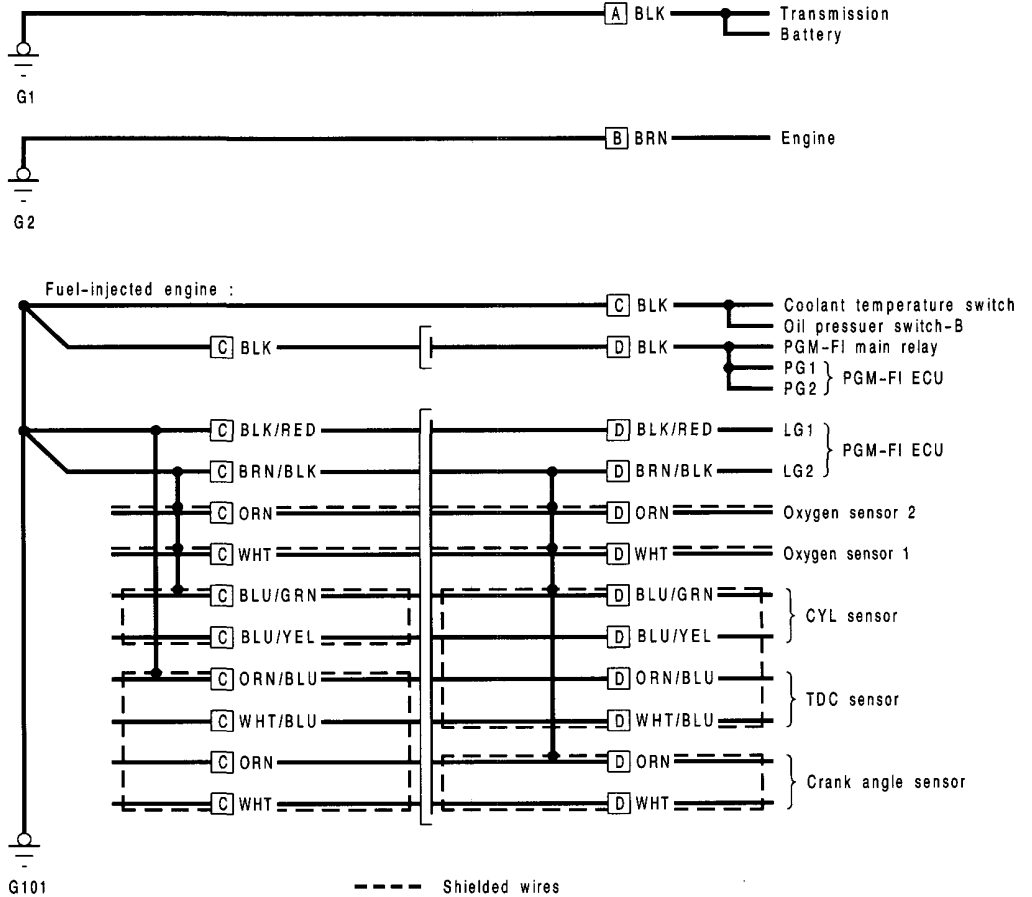

- A** : Battery ground wire
- B** : Engin ground wire
- C** : Engine wire harness
- D** : Main wire harness



RHD :

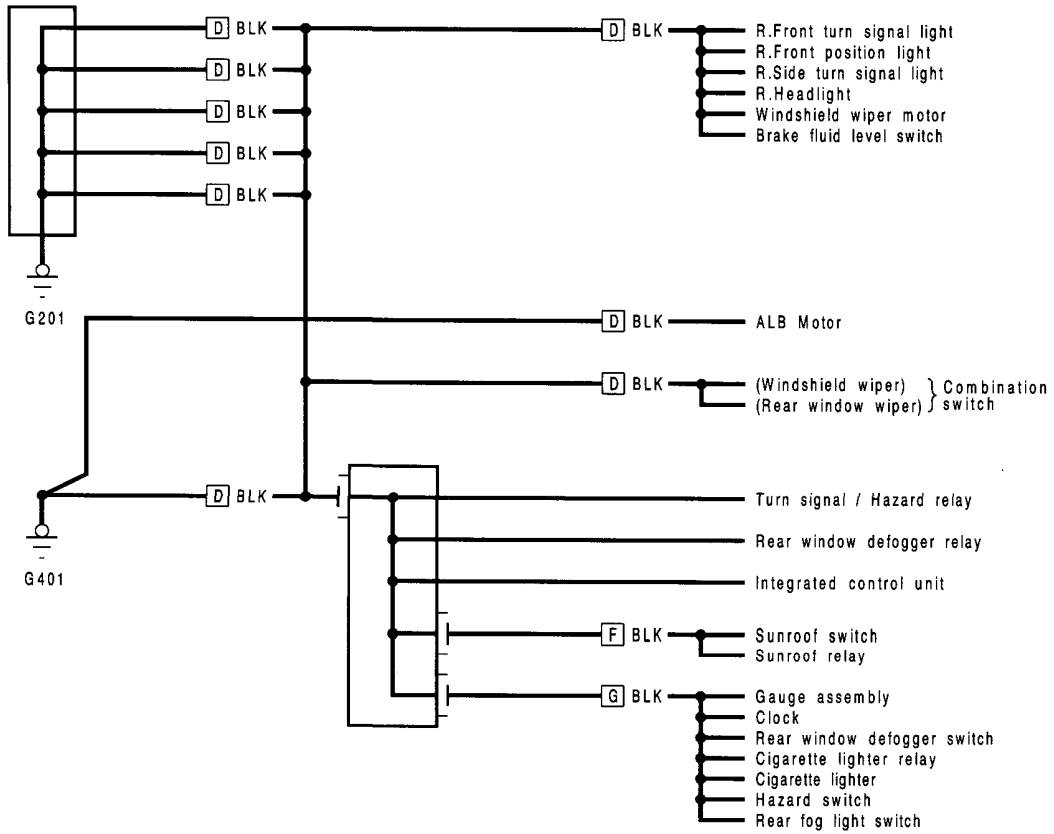

- C** : Engine wire harness
- D** : Main wire harness
- E** : Front Passenger's door wire harness
- F** : Roof wires
- G** : Dashboard wire harness
- J** : Rear wire harness

(cont'd)

Ground Distribution

Circuit Identification (cont'd)

RHD :

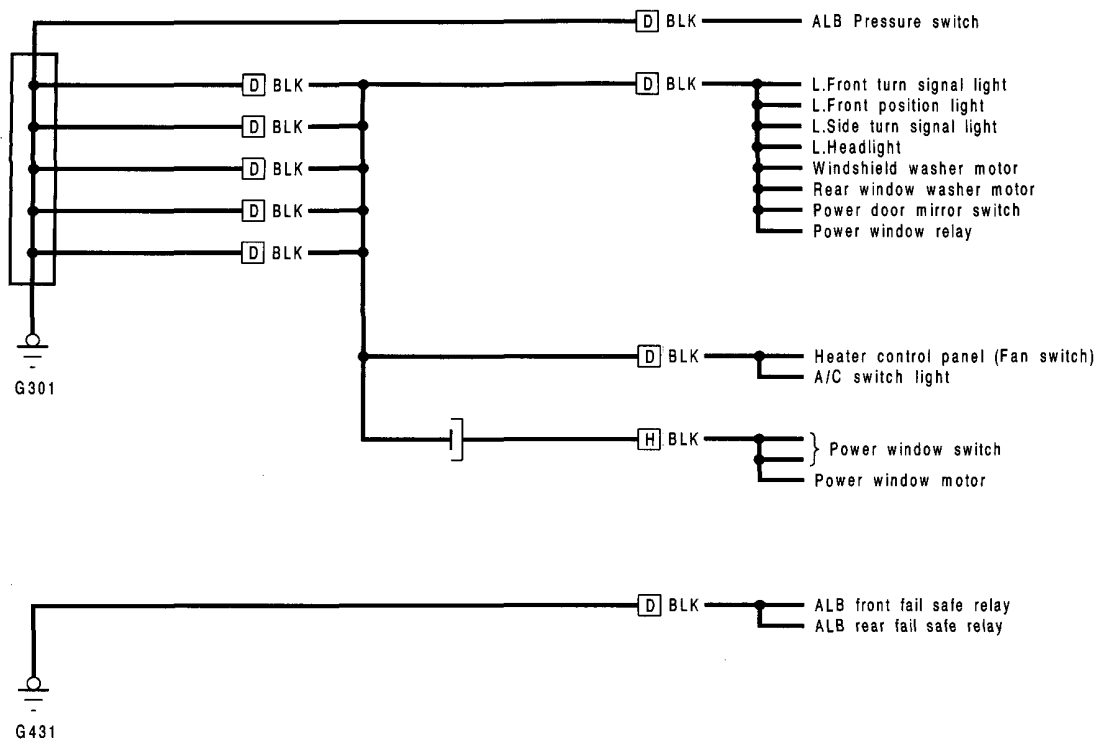

(Located left side, on the kick panel)

- D : Main wire harness
- H : Driver's door wire harness



LHD :

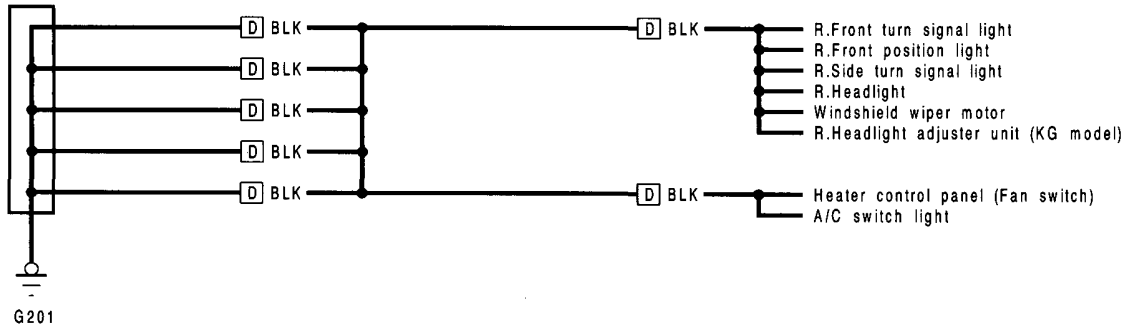

D : Main wire harness

(cont'd)

Ground Distribution

Circuit Identification (cont'd)

LHD :

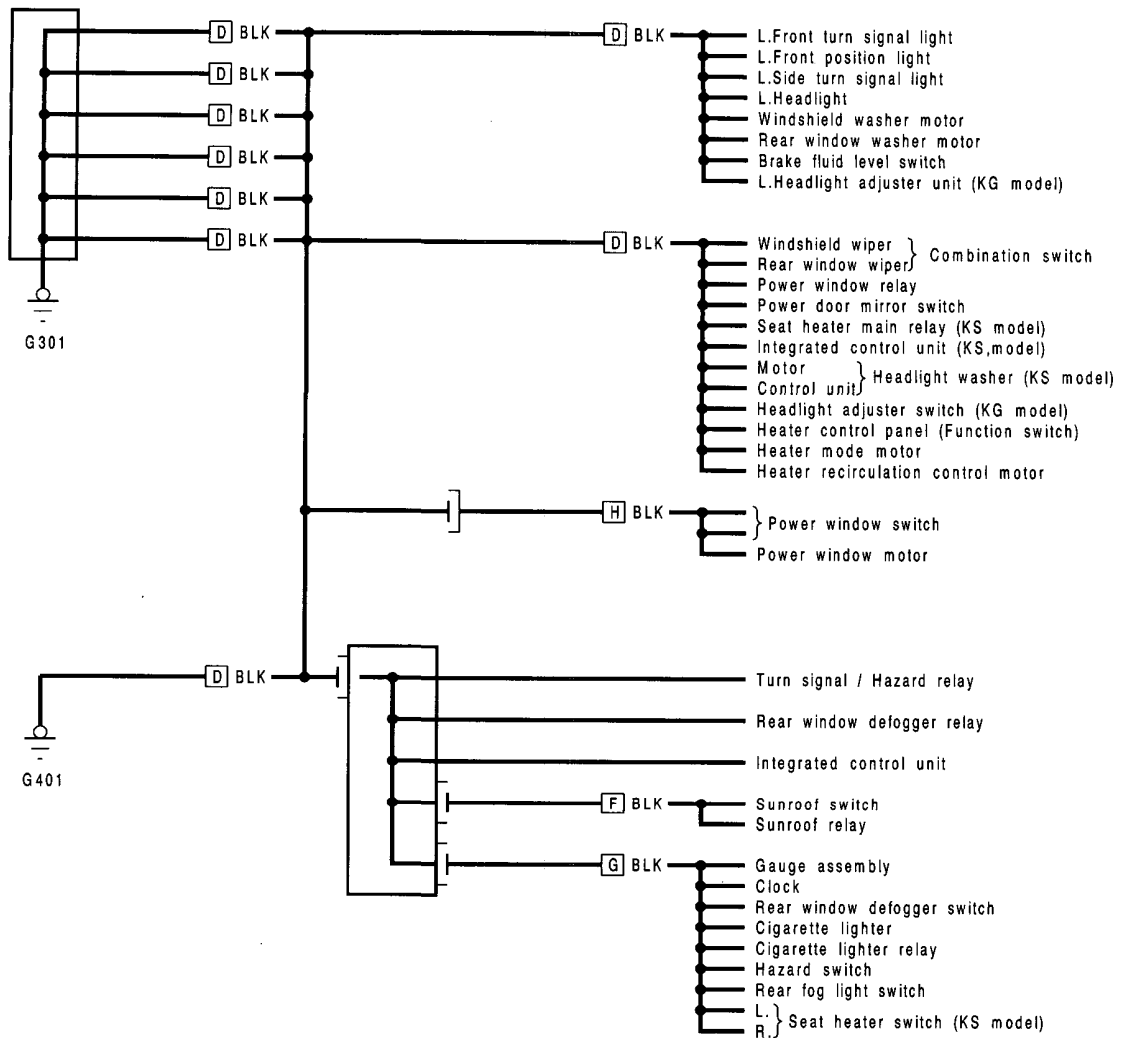

- D** : Main wire harness
- F** : Roof wires
- G** : Dashboard wire harness
- H** : Driver's door wire harness

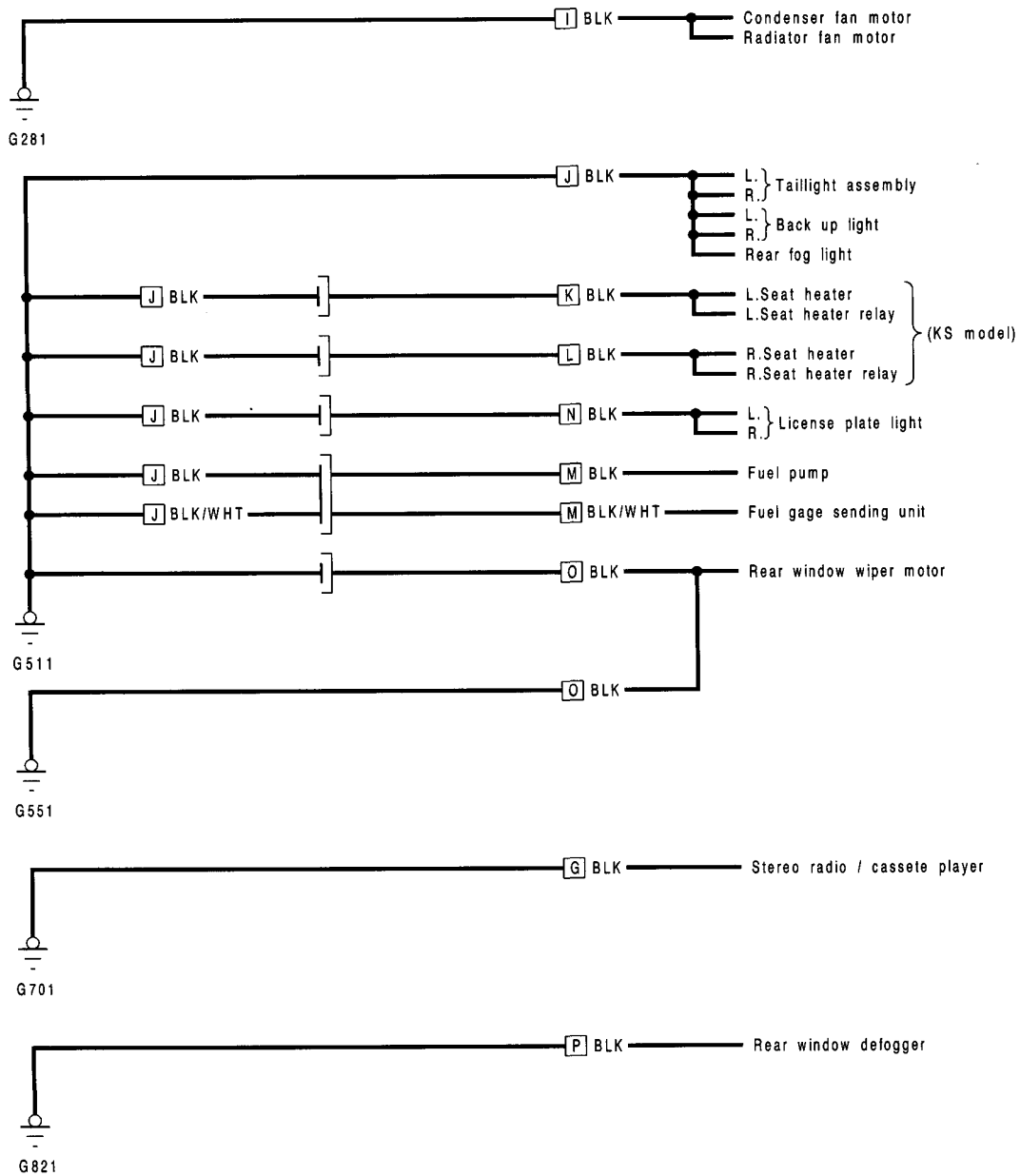

- | | | |
|------------------------------------|---------------------------------------|-----------------------------------|
| J : Rear wire harness | M : Fuel tank wires | P : Rear defogger sub cord |
| K : Left seat heater wires | N : License. plate light wires | |
| L : Right seat heater wires | O : Hatch wires | |