

Power Distribution

Circuit Identification

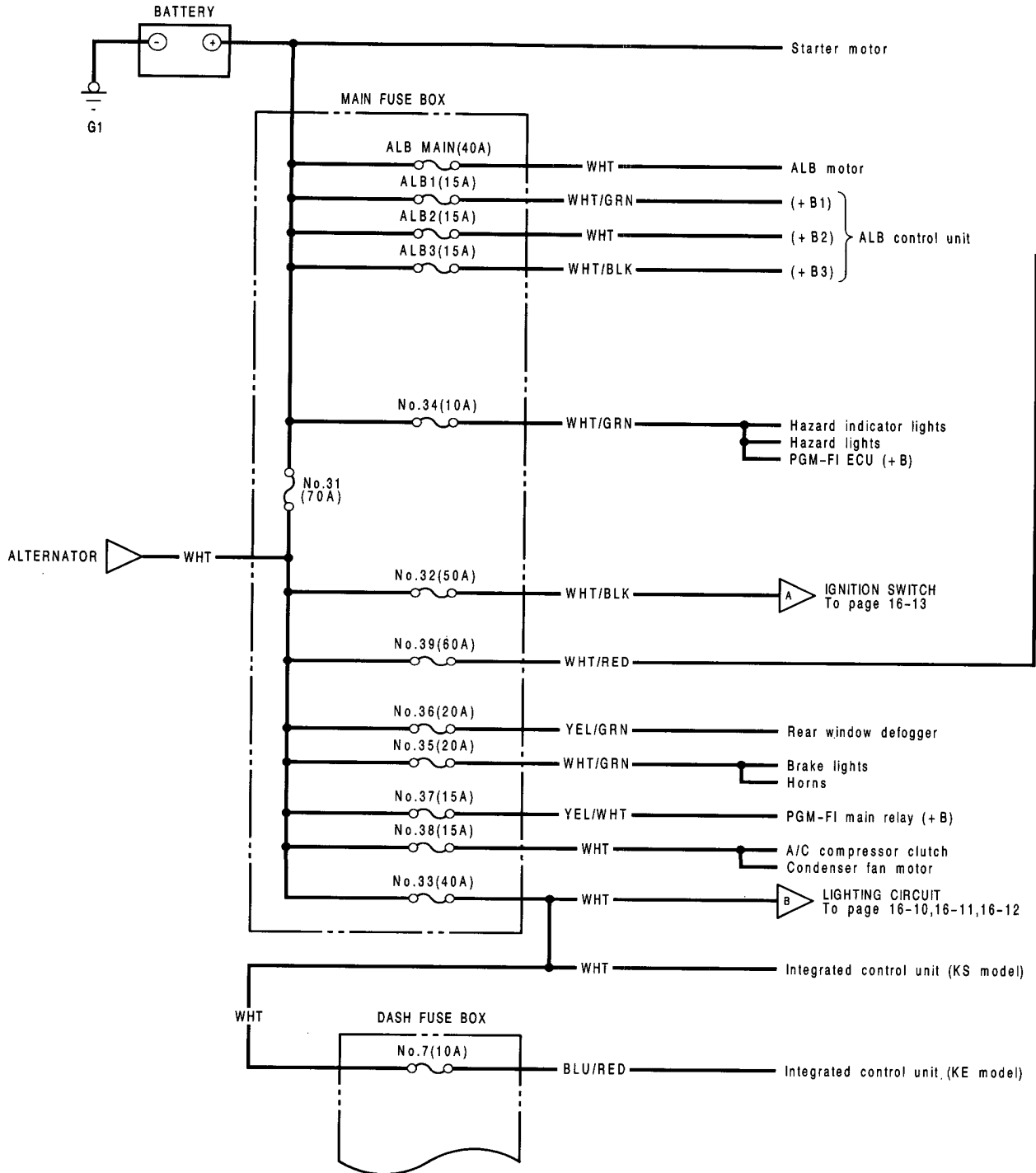

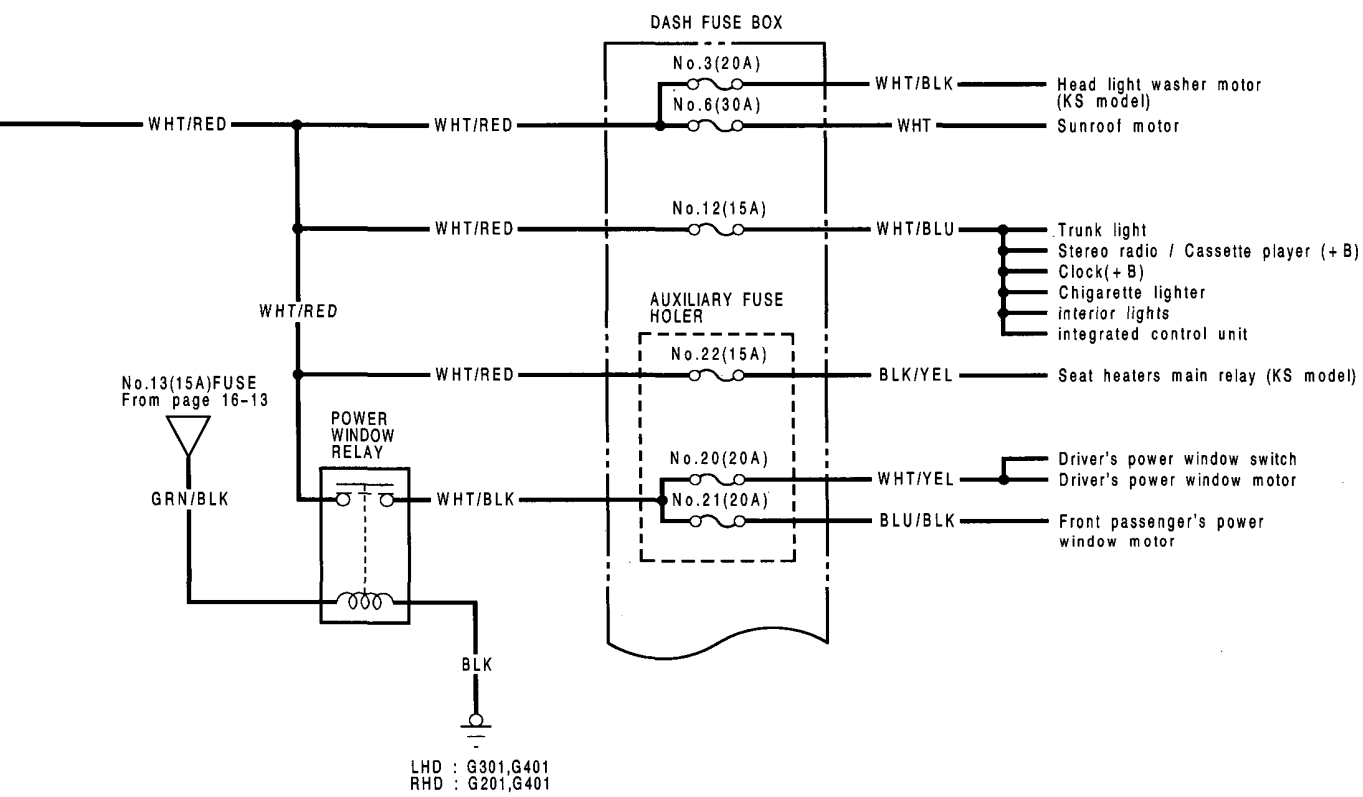

(cont'd)

Power Distribution

Circuit Identification (cont'd)

Except KE ,KS model

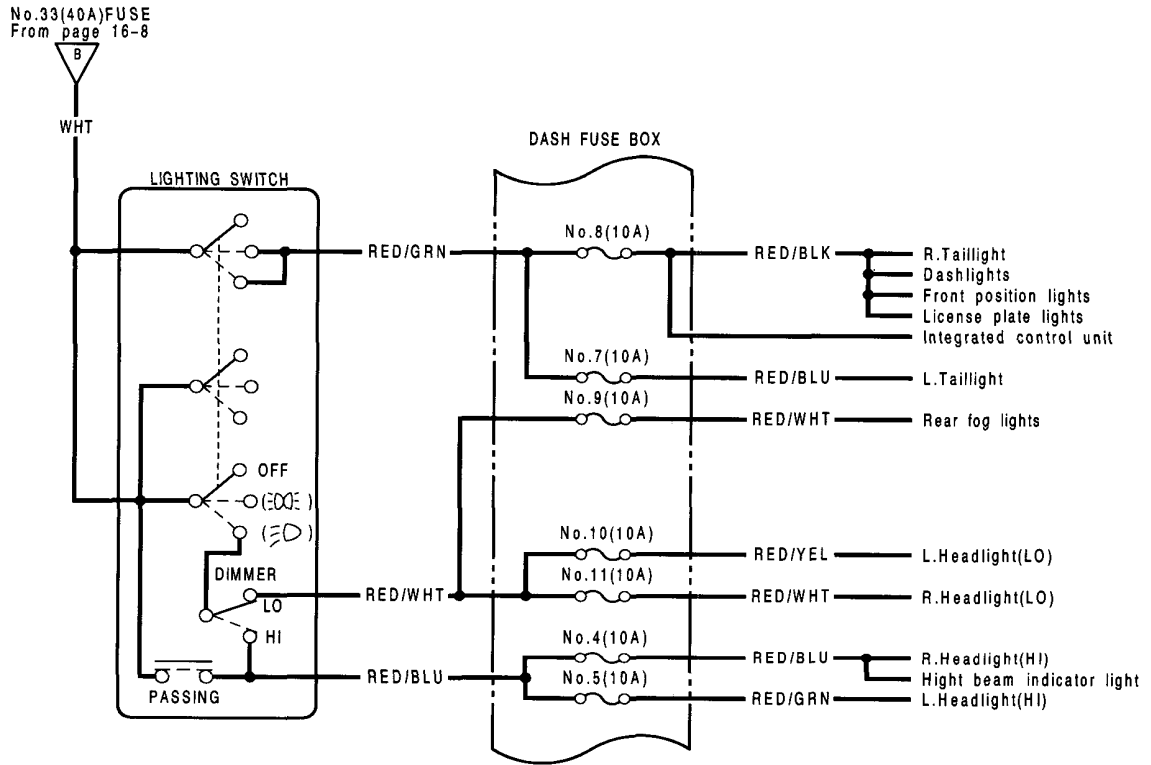



KS model:

No.33(40A) FUSE
From page 16-8

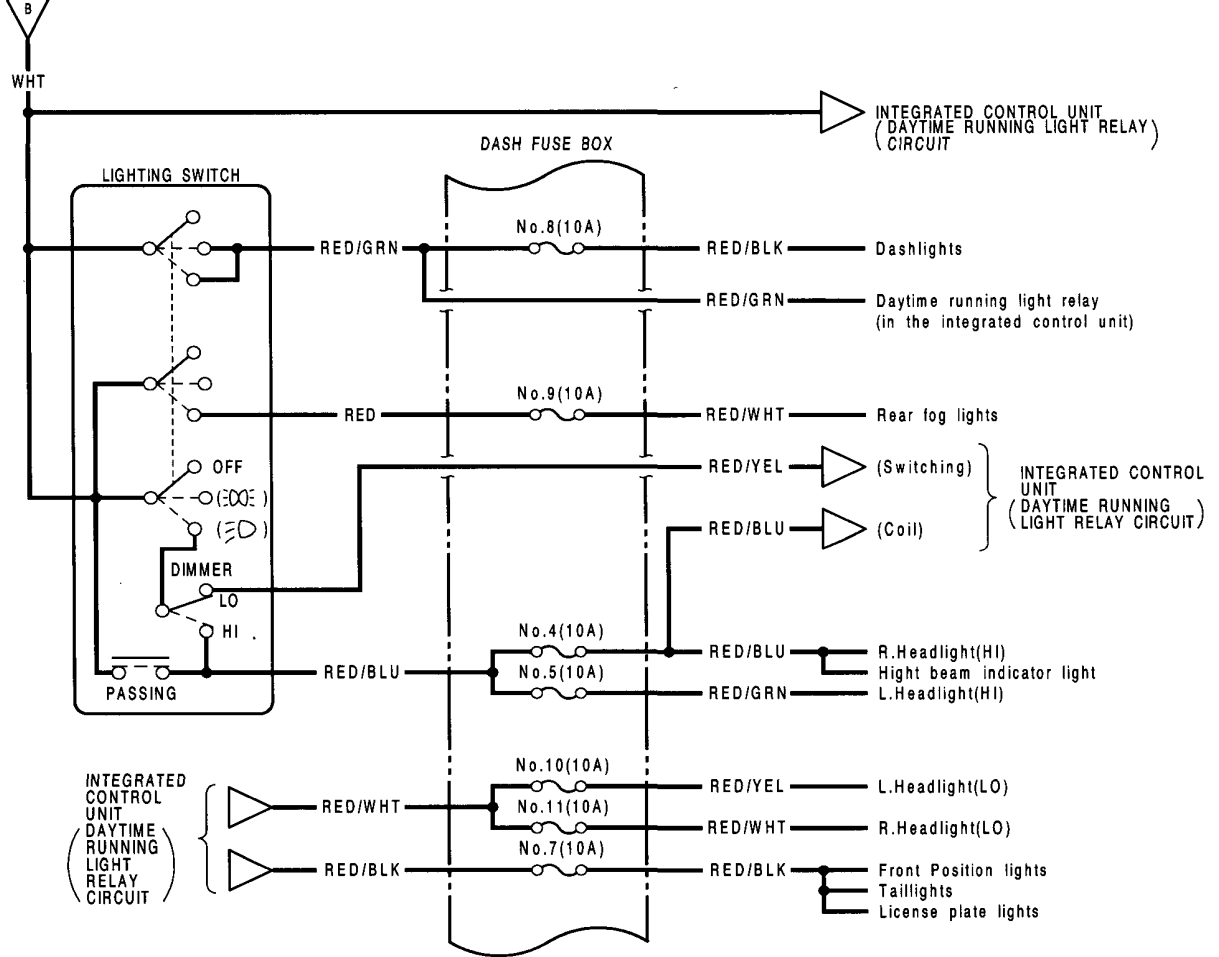

(cont'd)

Power Distribution

Circuit Identification (cont'd)

KE model

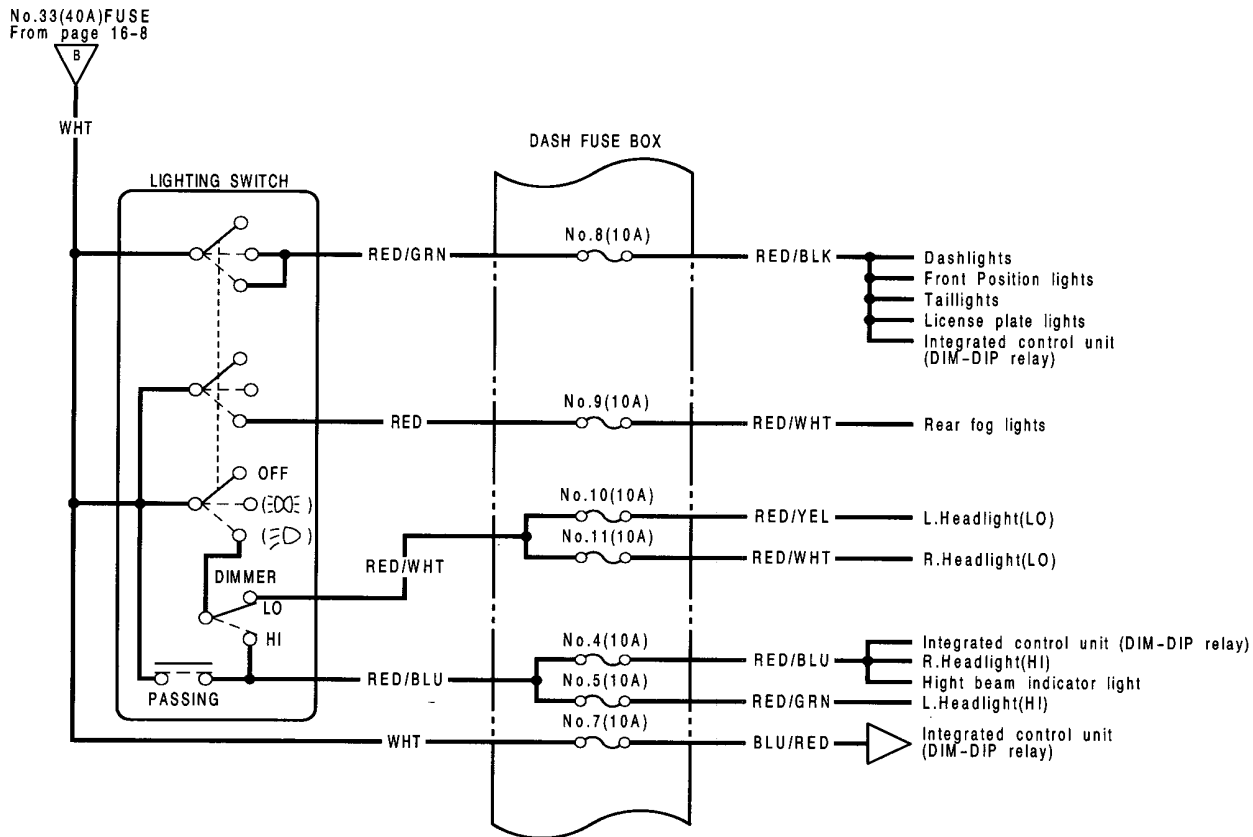



No.32(50A) FUSE
From page 16-8

