



Rocker Arm Inspection Using Special Tools

CAUTION:

- Before using the special tool (Valve Inspection Set), make sure that the air pressure gauge on the air compressor indicates over 245 kPa (2.5 kg/cm², 36 psi).
- Inspect the valve clearance before rocker arm inspection.
- Cover the timing belt with shop towel to prevent the belt.
- Check the mid rocker arm of each cylinder at TDC.

1. Remove the valve cover.
2. Plug the relief hole with the special tool (Air Stopper).

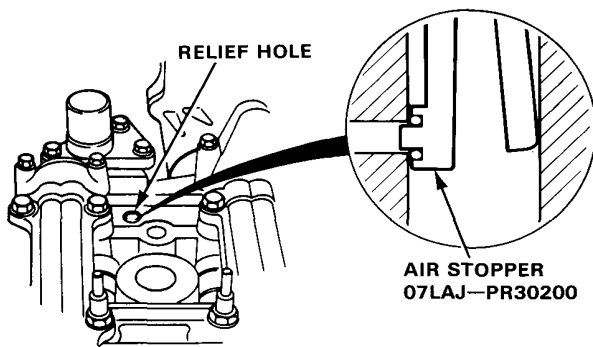

3. Remove the bolt and washer from the inspection hole and connect the special tool (Valve Inspection Set).

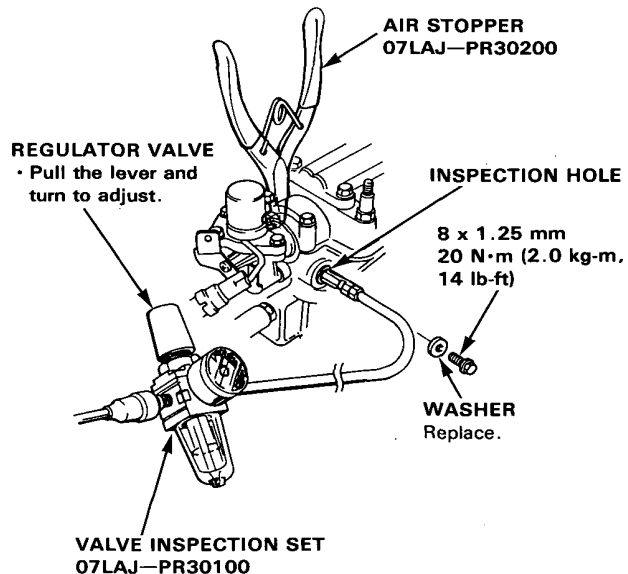

(cont'd)

Engine Tune-up

Rocker Arm Inspection Using Special Tools (cont'd)

4. Apply specified air pressure to the rocker arm pistons after loosening the regulator valve on the valve inspection set.

Specified Air Pressure:

245 kPa (2.5 kg/cm², 36 psi)

—490 kPa (5.0 kg/cm², 71 psi)

5. Make sure that the primary and secondary rocker arms are mechanically connected by pistons and that the mid rocker arms do not move when pushed manually.

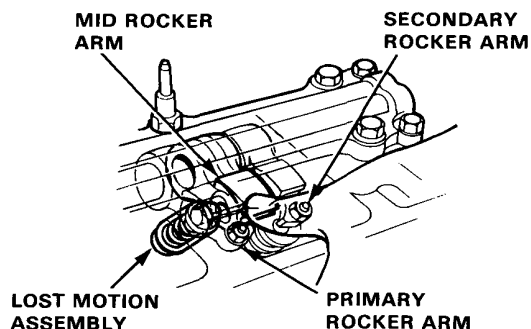

- If the mid rocker arms independently of the primary and secondary rocker arms, replace the rocker arms as a set.

6. Remove the special tools.
7. Check for smooth operation of the lost motion assembly. It is compressed slightly when the mid rocker arm is lightly pushed and compressed deeply when the mid rocker arm is strongly pushed.
 - Replace the lost motion assembly if it does not move smoothly.
8. After inspection, check that the ECU does not come on.