

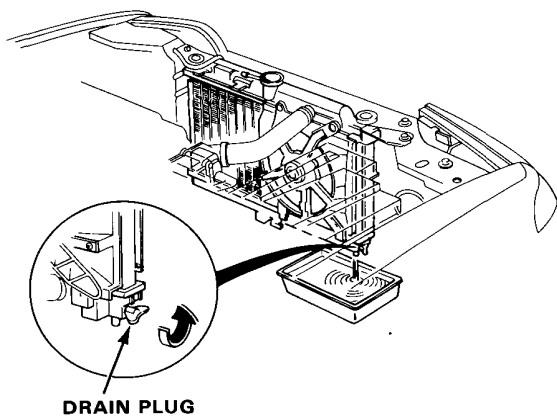

Refilling and Bleeding

CAUTION: When supplying coolant, be sure to shut the relay box lid and not to let coolant spill on the electrical parts or the painted portion. If any coolant spills, rinse it off immediately.

1. Set the heater temperature lever or control dial to maximum heat.
2. Remove the engine splash shield under the engine.
3. When the radiator is cool, remove the radiator cap. Loosen the drain plug, and drain the radiator.
4. Remove the drain bolt from the rear side of the cylinder block and heater.



DRAIN PLUG

5. Apply liquid gasket to the drain bolt threads, then reinstall the bolt with a new washer and tighten it securely.
6. Tighten the radiator drain plug securely.
7. Remove, drain and reinstall the reservoir. Fill the tank halfway to the MAX mark with water, then up to the MAX mark with coolant.
8. Mix the recommended anti-freeze with an equal amount of water in a clean container.

NOTE:

- Use only HONDA-RECOMMENDED anti-freeze/coolant.
- For best corrosion protection, the coolant concentration must be maintained year-round at 50 % MINIMUM. Coolant concentrations less than 50 % may not provide sufficient protection against corrosion or freezing.
- Coolant concentrations greater than 60 % will impair cooling efficiency and are not recommended.

CAUTION:

- Do not mix different brands of anti-freeze/coolants.
- Do not use additional rust inhibitors or anti-rust products; they may not be compatible with the recommended coolant.

Radiator Coolant Refill Capacity: including reservoir
(0.4 ℓ (0.4 US qt, 0.4 Imp qt)).
4.7 ℓ (5.0 US qt, 4.1 Imp qt).

9. Loosen the air bleed bolt in the water outlet, then fill the radiator to the bottom of the filler neck with the coolant mixture. Tighten the bleed bolt as soon as coolant starts to run out in a steady stream without bubbles.

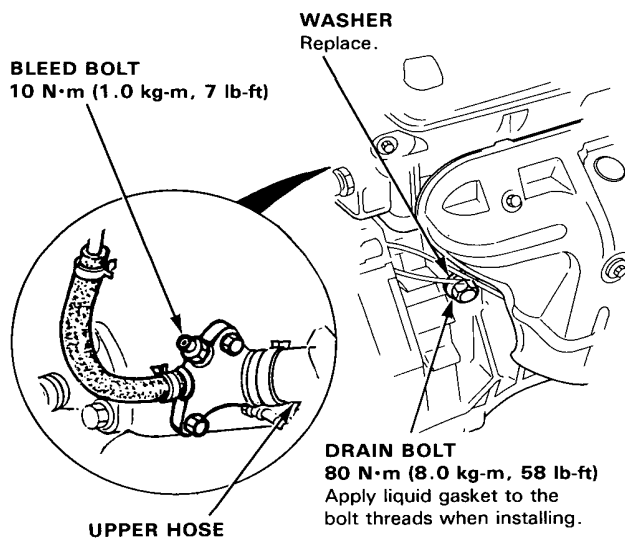

10. With the radiator cap off, start the engine and let it run until warmed up (fan goes on at least twice). Then, if necessary, add more coolant mix to bring the level back up to the bottom of the filler neck.
11. Put the radiator cap on, then run the engine again and check for leaks.