

Engine Removal/Installation



▲WARNING

- Make sure jacks and safety stands are placed properly and hoist brackets are attached to the correct positions on the engine (See section 1).
- Apply parking brake and block rear wheels, so the car will not roll off stands and fall while you are working under it.

CAUTION:

- Use fender covers to avoid damaging painted surfaces.
- Remove the wiring slowly while holding the connector portion to avoid disconnecting.
- Mount the wiring or tubes to avoid mis-connection. Also, be sure that they do not contact other cords or tubes or interference with other parts.

1. Disconnect the battery negative terminal first, then the positive terminal. Remove the battery.
CAUTION: Clean battery posts and cable terminals with sandpaper, assemble, then apply grease to prevent corrosion.
2. Fix the engine hood in a vertical position.
 - Do not remove the hood.

3. Drain the engine oil. Remove the oil filler cap to speed draining. Reinstall the drain plug using a new washer.
4. Drain the coolant from the radiator into a clean pan so it may be reused. Remove the radiator cap to speed draining.

▲WARNING

Use care when removing the radiator cap to avoid scalding by hot coolant or steam.

5. Remove the transmission under cover.
6. Drain transmission oil. Use a 3/8" drive socket wrench to remove the drain plug. Remove the oil filler plug or dipstick to speed draining. Reinstall the drain plug using a new washer.
7. Remove the air intake duct and air cleaner case.
8. Remove the battery base.
9. Relieve fuel pressure by slowly loosening the service bolt on the fuel pipe about one turn.

▲WARNING

Do not smoke while working on the fuel system. Keep open flame away from work area. Drain fuel only into an approved container.

CAUTION:

- Before disconnecting any fuel line, the fuel pressure should be relieved as described above.
 - Place a shop towel over the fuel filter to prevent pressurized fuel from spraying over the engine.
10. Remove the fuel feed hose.
 11. Disconnect the charcoal canister hose from throttle body.
 12. Disconnect the MAP sensor vacuum hose.

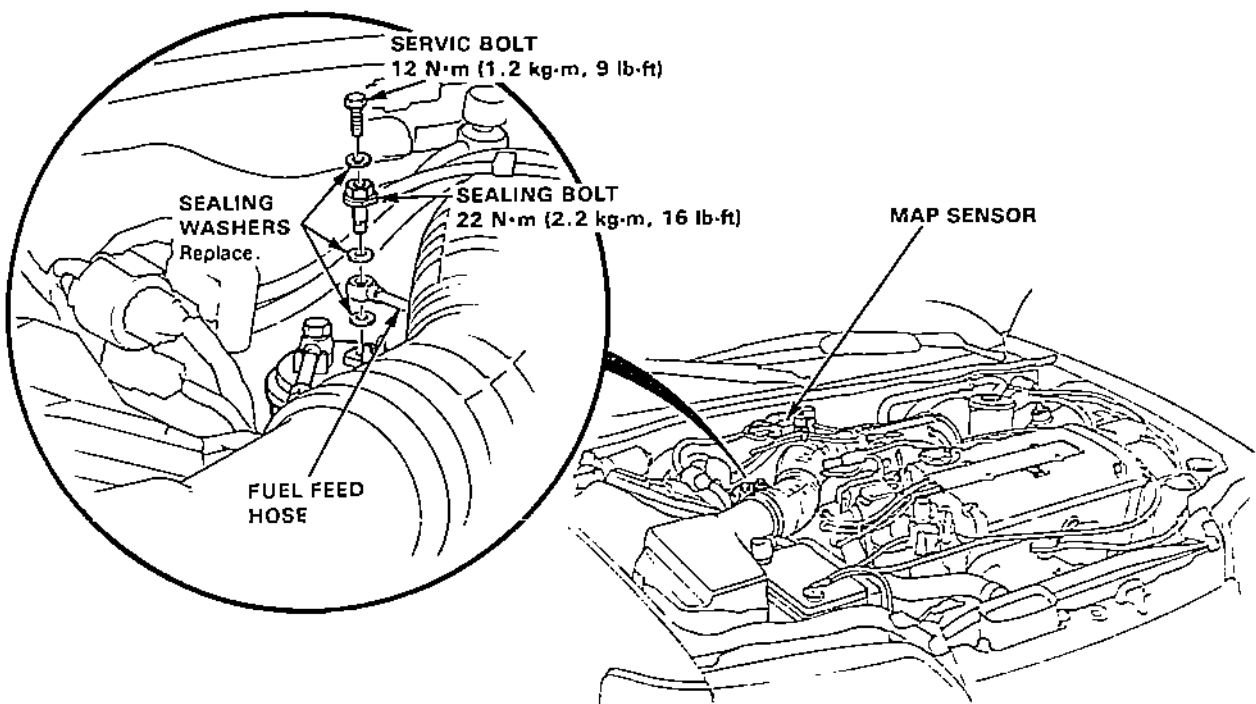

Engine Removal/Installation

(cont'd)

13. Disconnect the three engine compartment harness connectors, then remove the battery wires from the under hood fuse box.
14. Remove the transmission ground cable.

15. Remove the cap and bolts, then remove distributor from the cylinder head.
NOTE: Adjust the ignition timing, when installing the distributor.

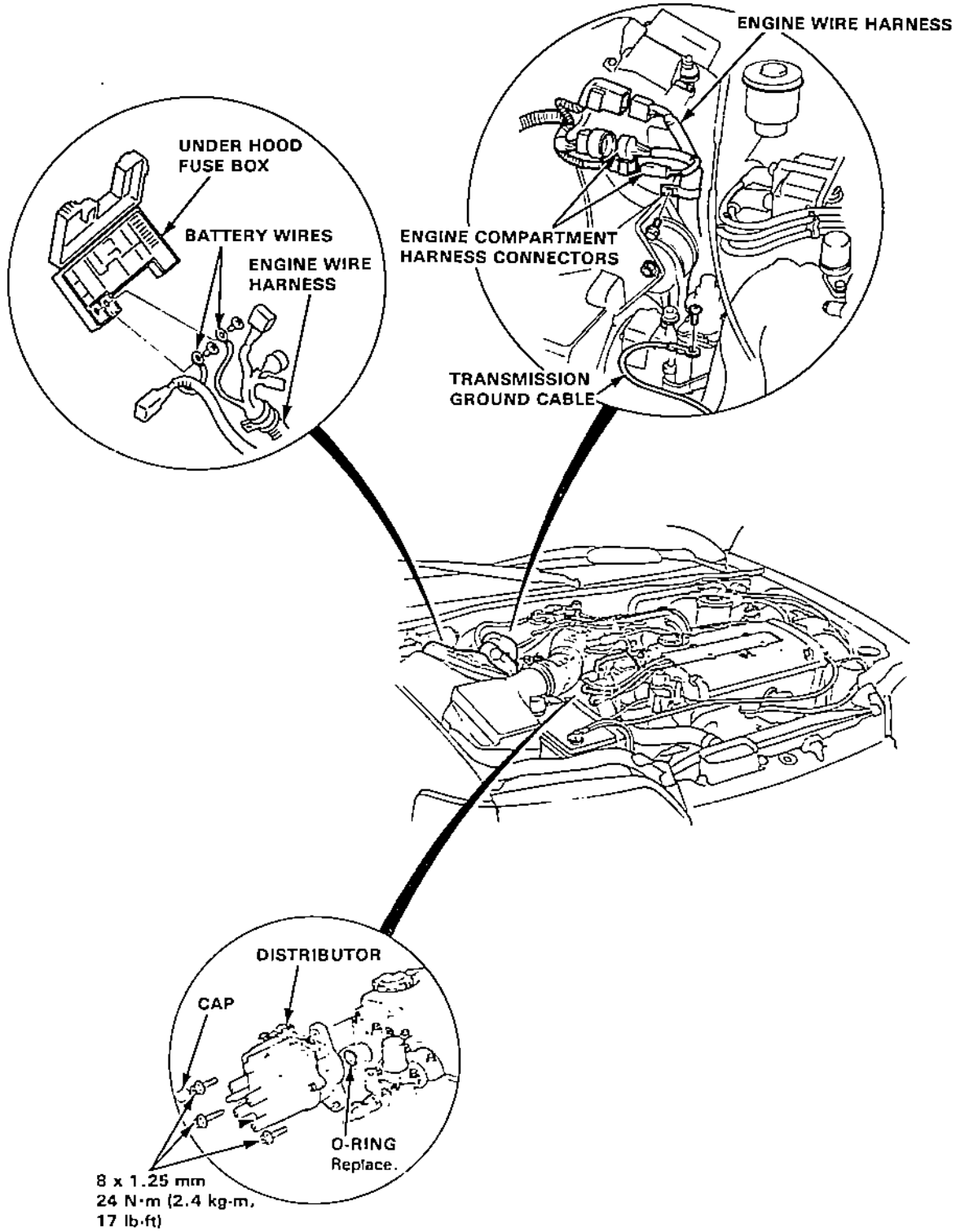



16. Remove the throttle cable by loosening the locknut, then slip the cable end out of the throttle bracket and throttle linkage.

NOTE: Take care not to bend the cable when removing it. Do not use pliers to remove the cable from the linkage. Always replace a kinked cable with a new one.

17. Remove the fuel return hose.

18. Remove the brake booster vacuum hose from the intake manifold.

19. Disconnect the two engine wire harness connectors from main wire harness at the left side of the engine compartment.

20. Remove the engine ground wire from the front upper bulkhead.

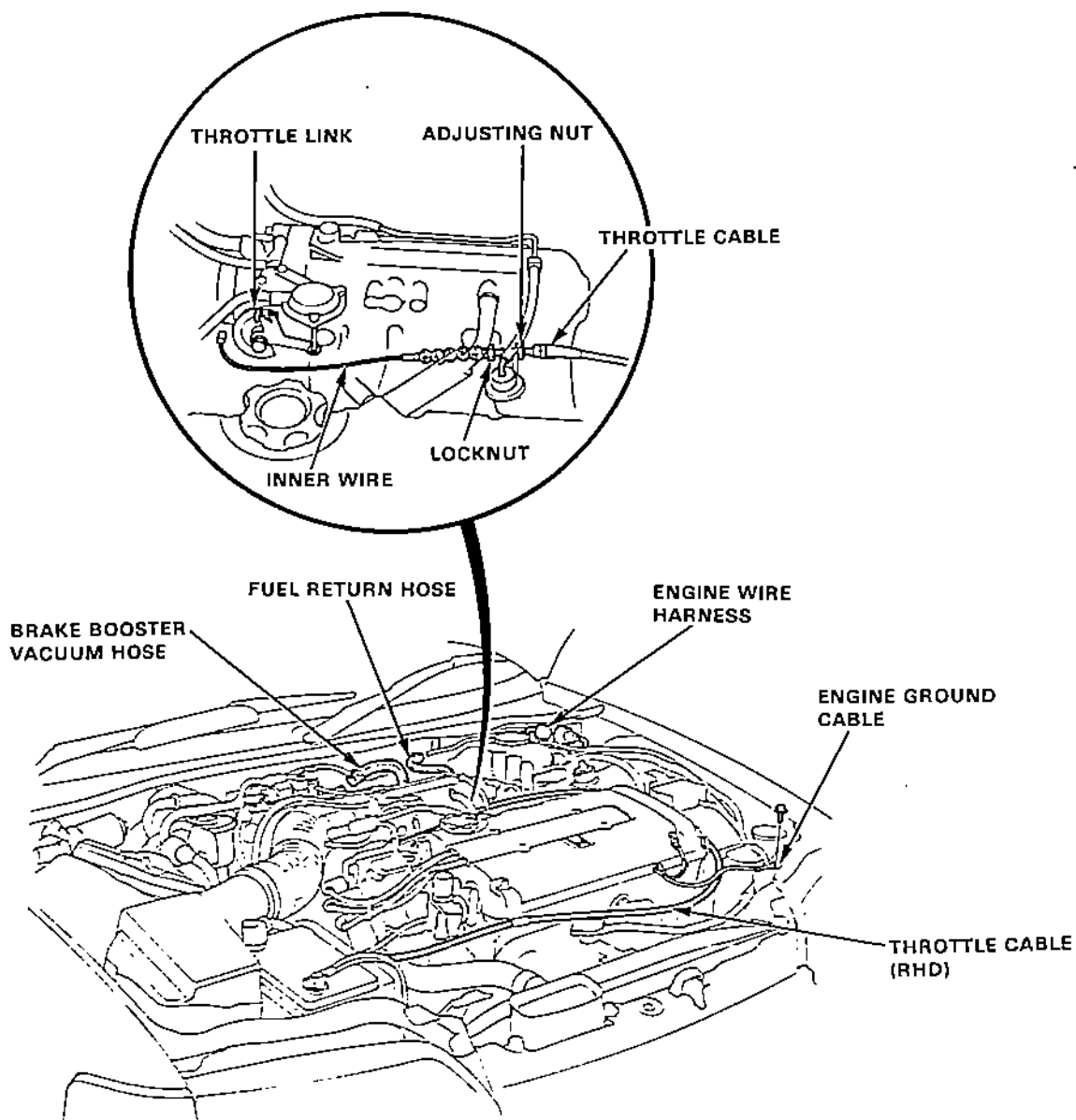

Engine Removal/Installation

(cont'd)

21. Remove the radiator upper hose and the heater inlet hose from cylinder head, then remove the radiator lower hose and the heater outlet hose from thermostat housing.

22. Remove the speedometer cable.

CAUTION: Do not remove the holder because the speedometer gear may fall into the transmission housing.

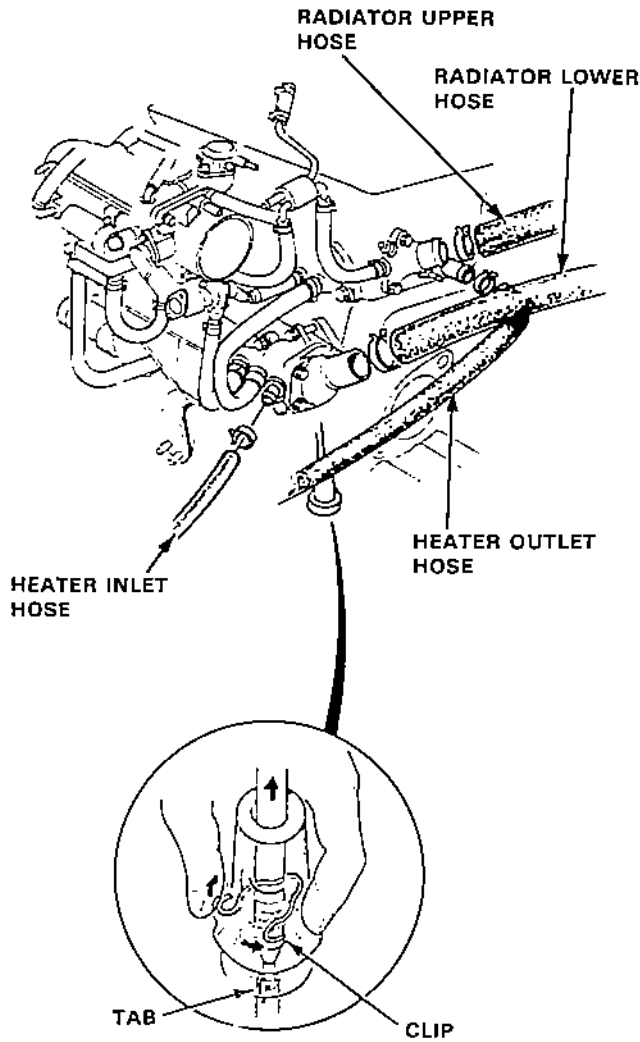

During Installation:

- Align tab on cable end with slot in holder.
- Install clip so bent leg is on groove side. After installing, pull speedometer cable to make sure it is secure.

23. Remove the radiator.

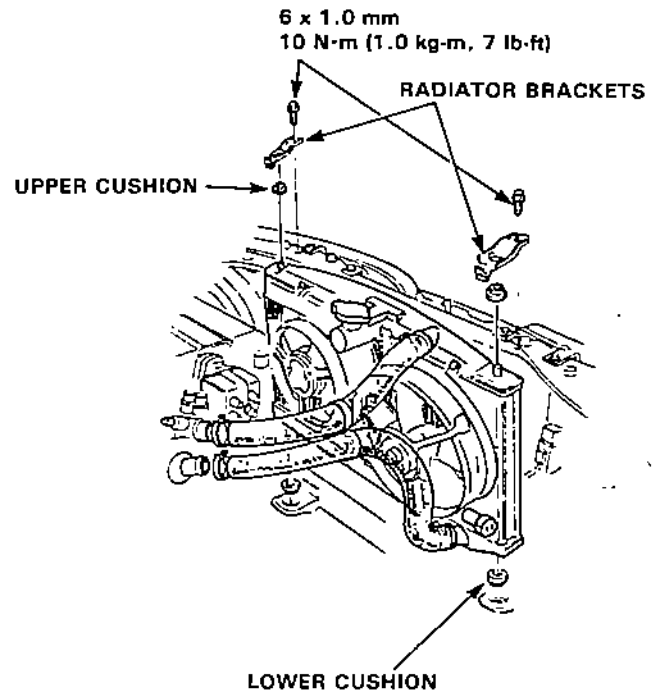



Air conditioner equipped cars:

24. Loosen the belt adjusting bolt and the idle pulley bolt, then remove the A/C belt.

25. Remove the compressor mount bolts, then lift the compressor out of the bracket with hoses attached, and wire it up to the front beam.

NOTE: The compressor can be moved without discharging the air conditioner system.

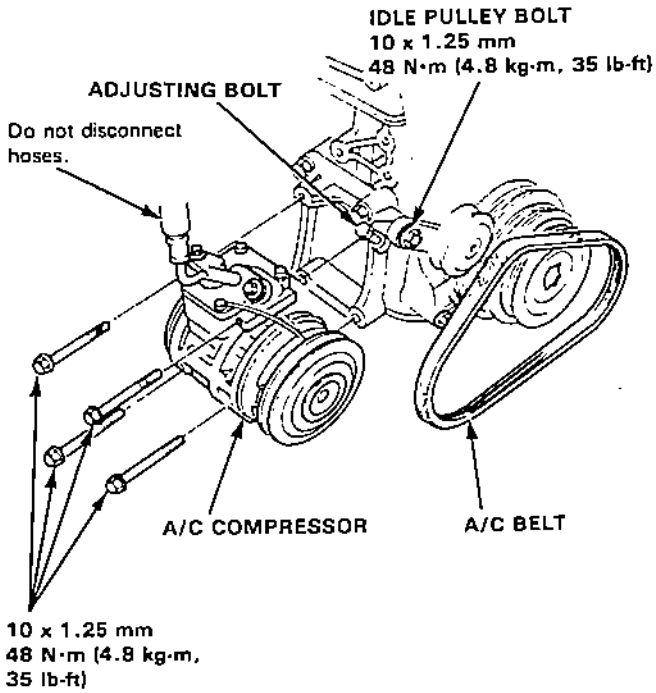

26. Remove the alternator: (LHD and RHD with ALB only)

- Disconnect the alternator wire harness connectors.
- Remove the adjust bolt and remove the belt.
- Remove the belt alternator mount bolt and remove the alternator.

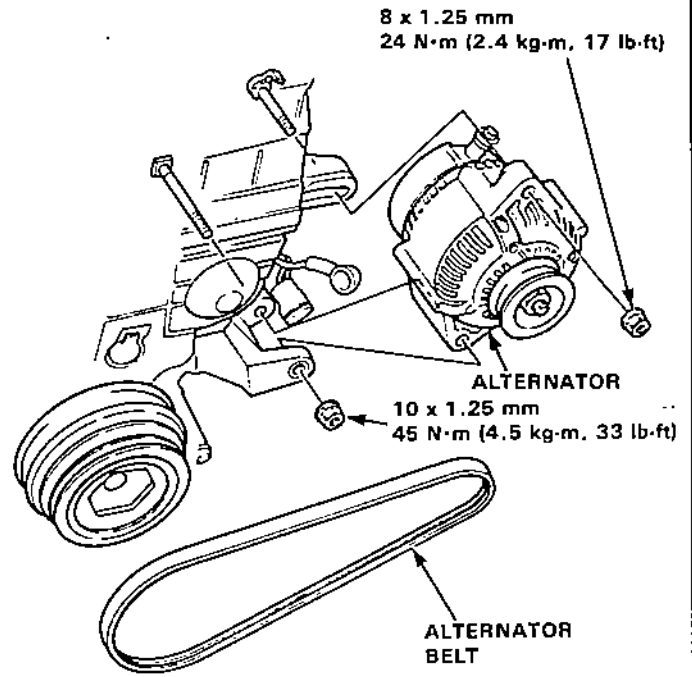

Engine Removal/Installation

(cont'd)

27. Remove the splash shields.
28. Remove the exhaust pipe A self-locking nuts and bracket mounting bolts.

CAUTION:

 - Remove the oxygen sensors before disconnecting the exhaust manifold and the exhaust pipe A.
 - Do not use air wrench or hammer for disconnecting the exhaust manifold and the exhaust pipe A, if the oxygen sensors are not to be removed.
29. Remove the ball joints from the tie-rod ends and suspension lower arms.
30. Remove the driveshafts.

31. Remove the clutch cable adjusting nut.

NOTE: On assembly, check the cable adjustment (Section 7).
32. Remove the shift rod and the shift lever rod.

NOTE: On assembly, slide the retainer back into place after driving in the spring pin.

NOTE: Coat all precision finished surfaces with clean engine oil or grease. Tie plastic bags over the driveshaft ends.

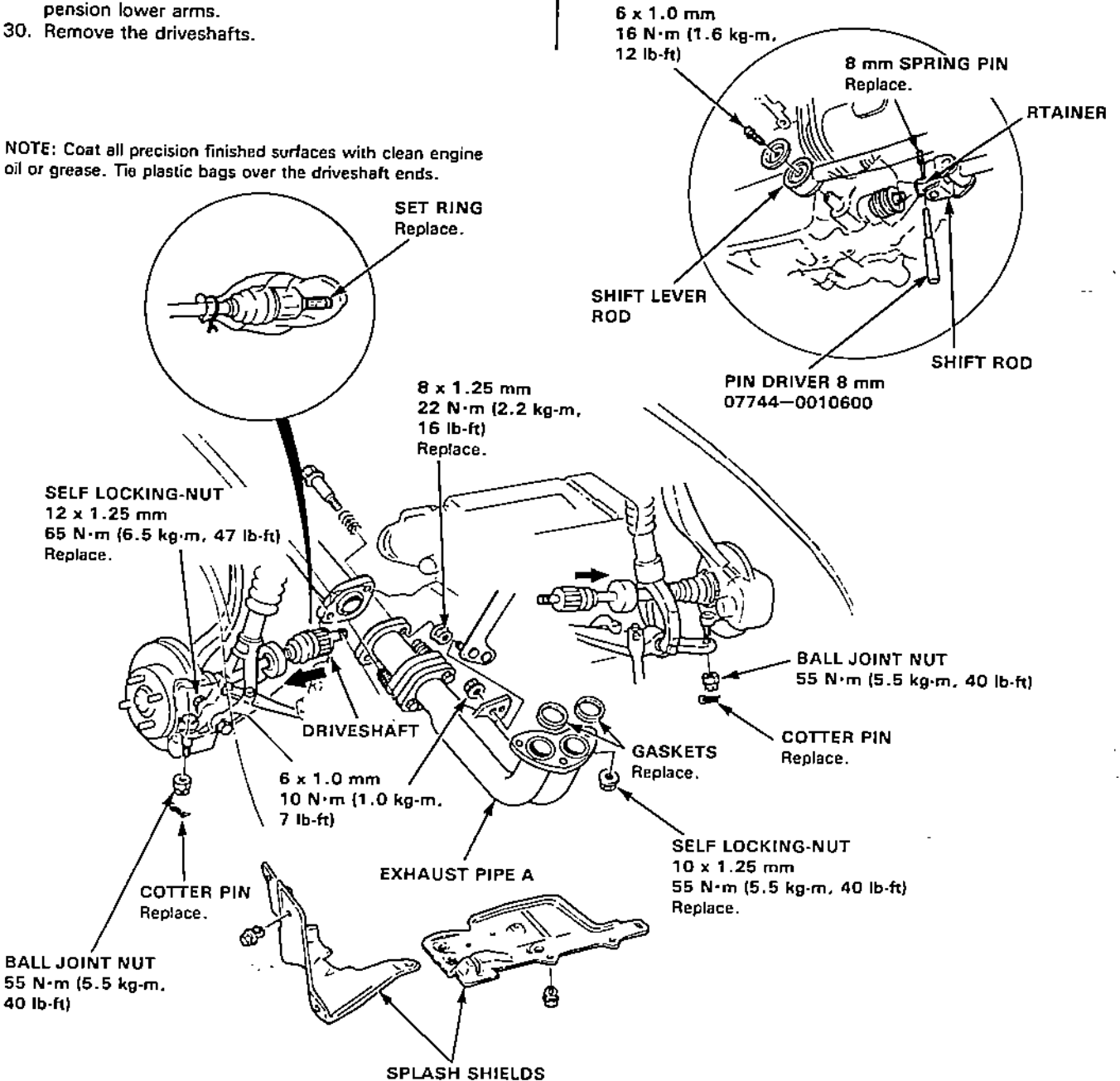



▲ WARNING Do not get under the engine when hoisting the engine.

33. Attach a special tool set to the engine. Raise the hoist to remove all slack from the chain.
34. Remove the rear engine mount, mounting bracket and mounting bolt.
35. Remove the front engine mount and mounting bolt.
36. Remove the side transmission mount, mounting bracket and mounting bolt.

37. Remove the side engine mounting bolt.
38. Check that the engine/transaxle is completely free of vacuum hoses, fuel and coolant hoses, and electric wires.
39. Slowly raise the engine approximately 6" Check once again that all hoses and wires have been disconnected from the engine/transaxle.
40. Raise the engine/transaxle all the way and remove it from the car.

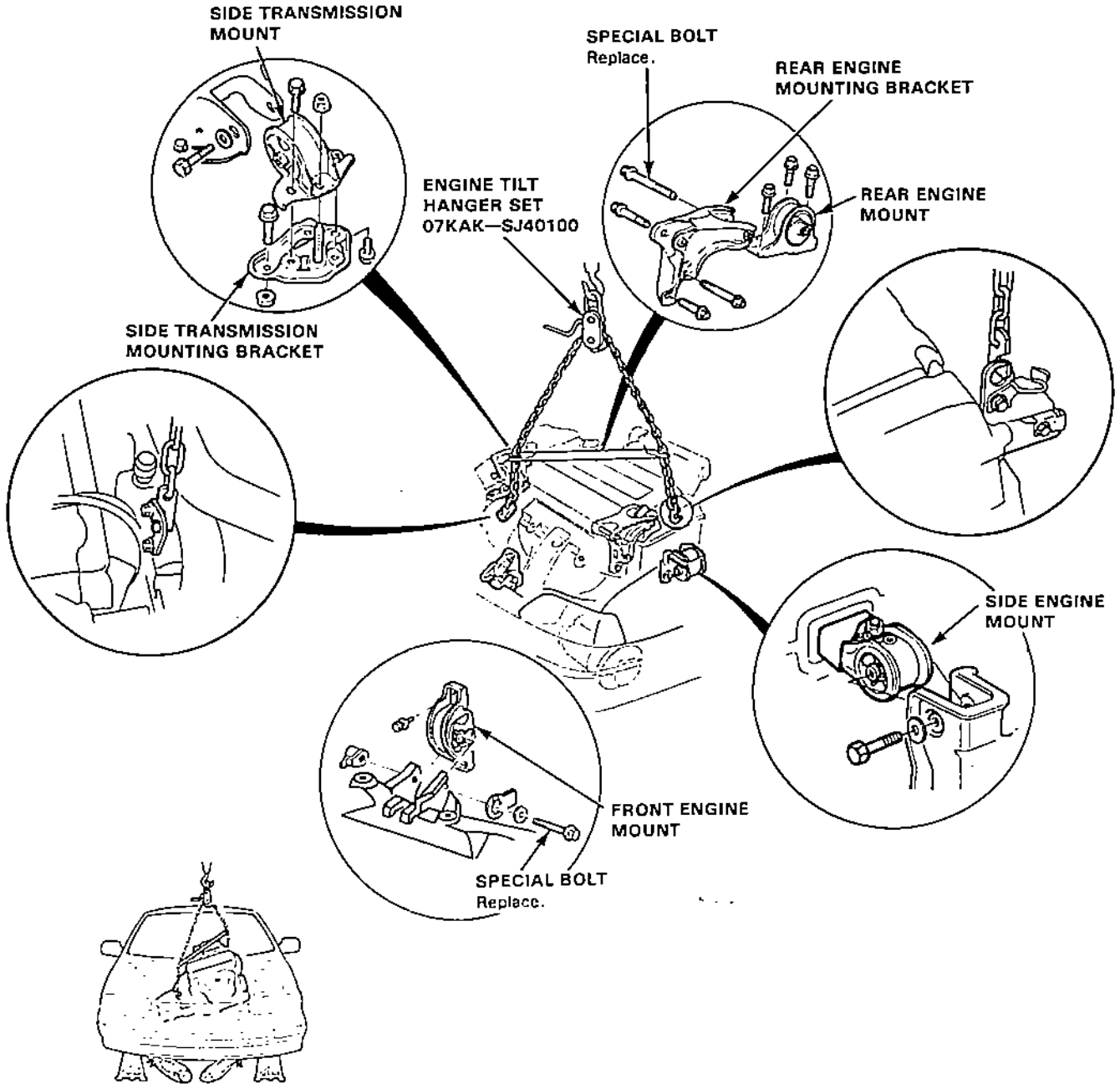

Engine Removal/Installation

(cont'd)

44. Install the engine in the reverse order of removal. After the engine in place:

- Torque the engine mounting bolts in sequence shown below.

CAUTION: Failure to tighten the bolts in the proper sequence can cause excessive noise and vibration, and reduce bushing life: check that the bushings are not twisted or offset.

- Check that the spring clip on the end of each driveshaft clicks into place.

CAUTION: Use new spring clips on installation.

- Bleed air from the cooling system at the bleed bolt with the heater valve open.

- Adjust the throttle cable tension.

- Check the clutch pedal free play.
- Check that the transmission shifts into gear smoothly.
- Adjust the alternator belt.
- Clean battery posts and cable terminals with sandpaper, assemble, then apply grease to prevent corrosion.
- Inspection for fuel leakage.

After assembling fuel line parts, turn on the ignition switch (do not operate the starter) so that the fuel pump is operated for approximately two seconds and the fuel is pressurized. Repeat this operation two or three times and check whether any fuel leakage has occurred at any point in the fuel line.

Engine Mounting Torque Sequence:

CAUTION: After loosening the special bolts, be sure to replace them with new ones.

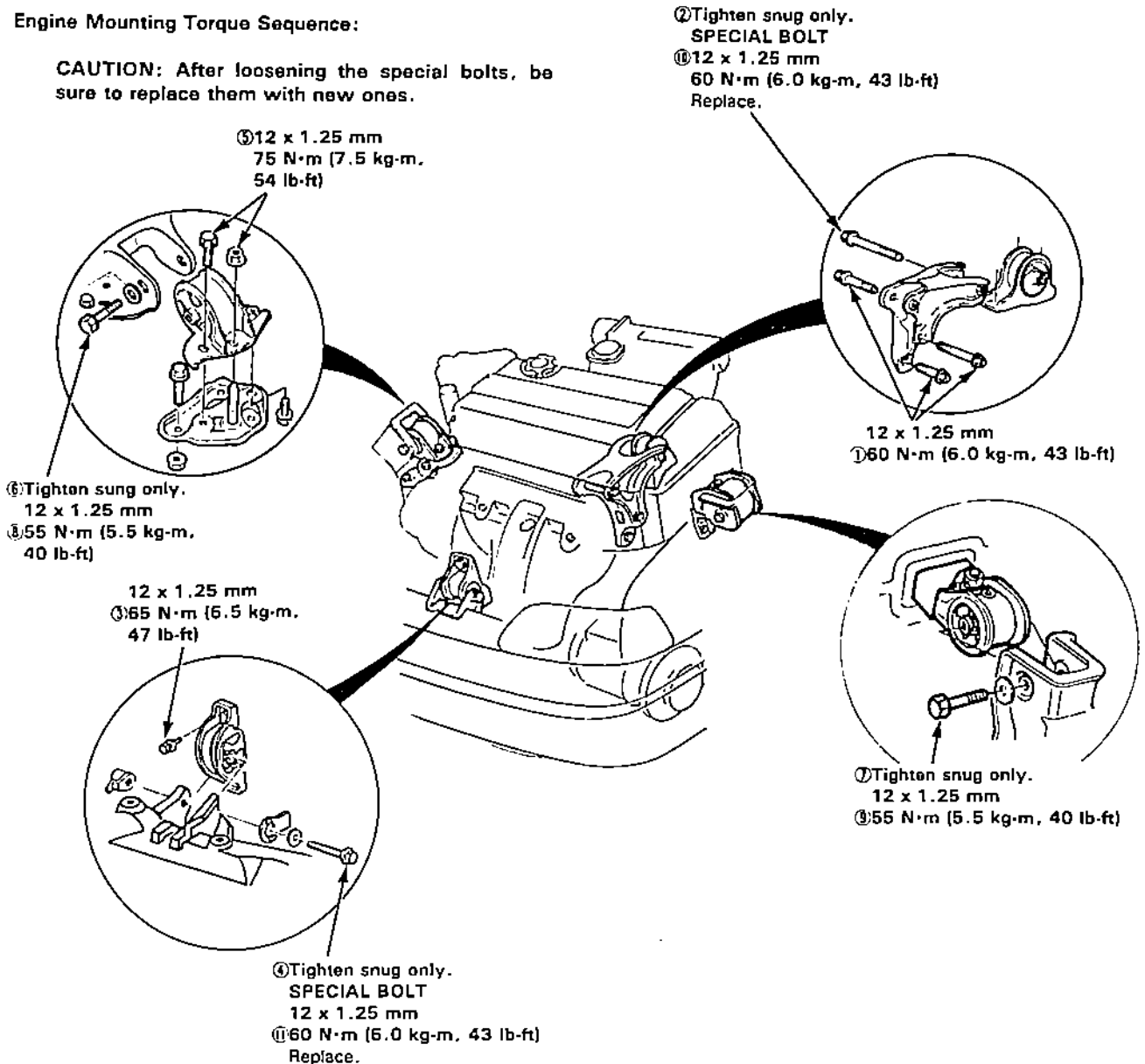



Additional Torque Value Specifications:

NOTE: For manifold replacement, refer to page 5-54.

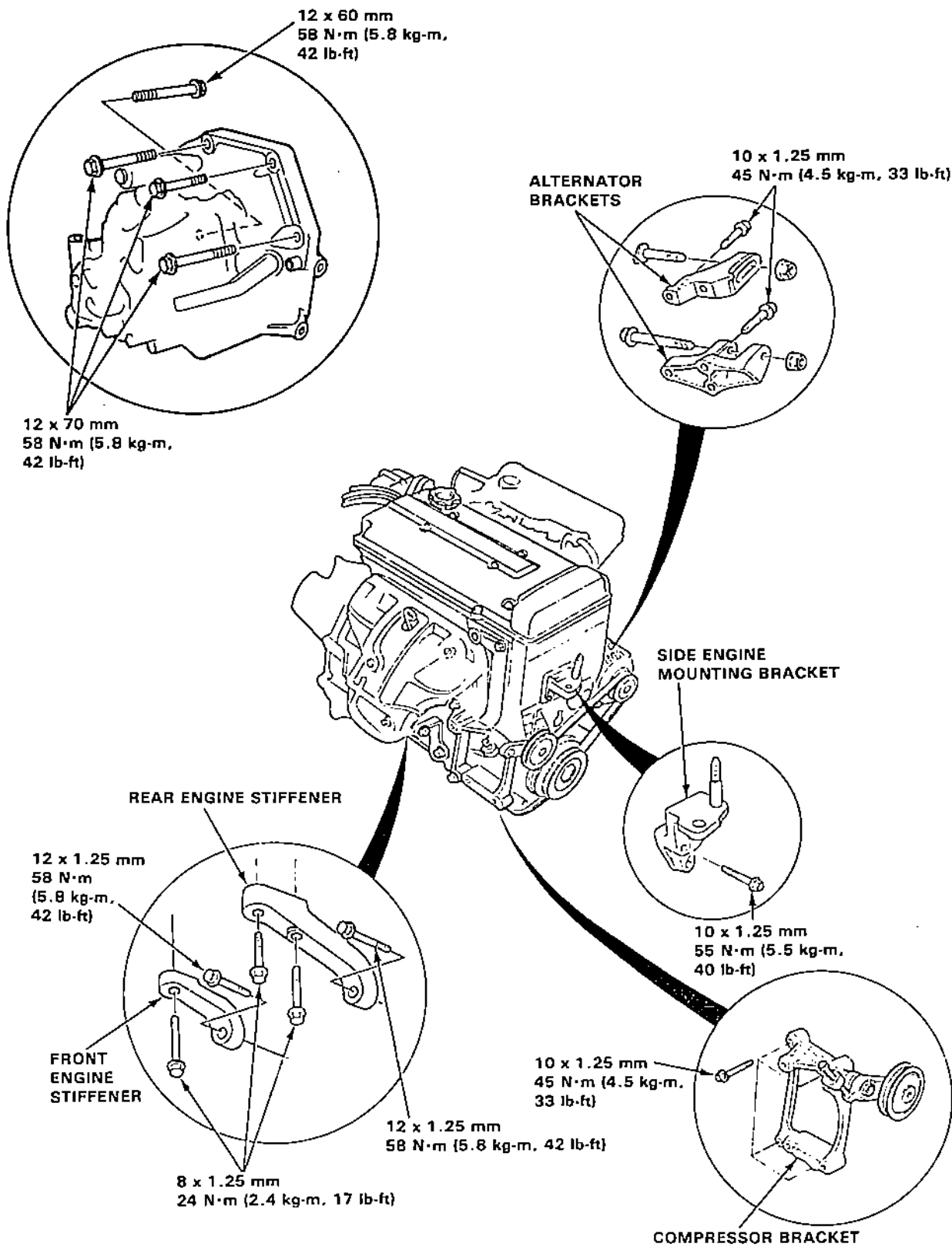

(cont'd)

Engine Removal/Installation

(cont'd)

Subframe Torque Value Specifications:

CAUTION: After loosening the special bolts, be sure to replace them with new ones.

