

Troubleshooting

Self-diagnostic Procedure

When the Check Engine warning light has been reported on, turn the ignition on, pull down the passenger's side carpet from under the dashboard and observe the LED on the top of the ECU. The LED indicates a system failure code by blinking frequency. The ECU LED can indicate any number of simultaneous component problems by blinking separate codes, one after another. Problem codes 1 through 9 are indicated by individual short blinks. Problem codes 10 through 44 are indicated by a series of long and short blinks. One long blink equals 10 short blinks. Add the long and short blinks together to determine the problem code.

NOTE: Information on this page is for LH and RH models.

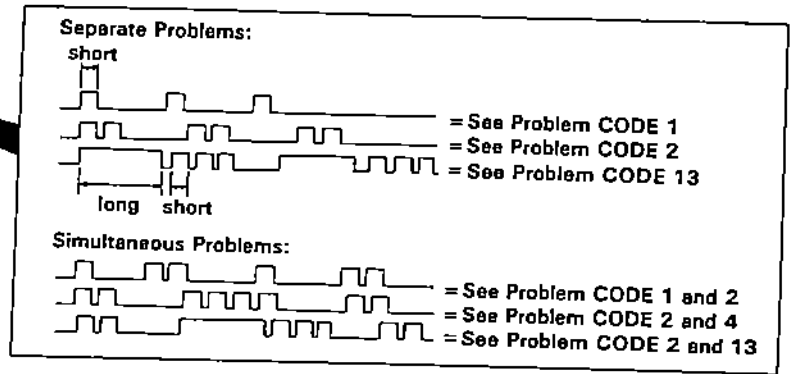
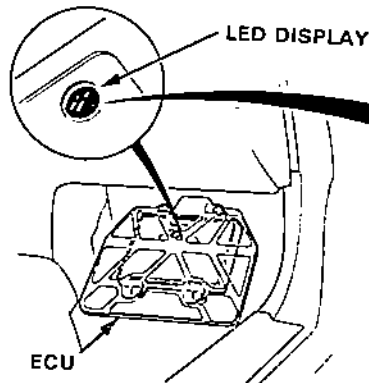

SELF-DIAGNOSIS INDICATOR BLINKS	SYSTEM INDICATED	PAGE
0	ECU	6-15
1, 2	OXYGEN CONTENT	6-18
3	MANIFOLD ABSOLUTE PRESSURE	6-22
5		6-26
4	CRANK ANGLE	6-28
6	COOLANT TEMPERATURE	6-34
7	THROTTLE ANGLE	6-36
8	TDC POSITION	6-30
9	No.1 CYLINDER POSITION	6-32
10	INTAKE AIR TEMPERATURE	6-38
13	ATMOSPHERIC PRESSURE	6-40
14	ELECTRONIC AIR CONTROL	6-47
15	IGNITION OUTPUT SIGNAL	6-42
17	VEHICLE SPEED SENSOR	6-44
21	SPOOL SOLENOID VALVE	5-32
22	OIL PRESSURE SWITCH	5-34
43, 44	FUEL SUPPLY SYSTEM (KX, KS, KG)	6-20

If codes other than those listed above are indicated, count the number of blinks again. If the indicator is in fact blinking unusual codes, substitute a known-good ECU and recheck. If the indication goes away, replace the original ECU. The Check Engine warning light and ECU LED may come on, indicating a system problem, when, in fact, there is a poor or intermittent electrical connection. First, check the electrical connections, clean or repair connections if necessary. If the Check Engine warning light is on and LED stays on, replace the ECU.



If the inspection for a particular failure code requires the PGM-FI test harness, remove the right door sill molding, the small cover on the right kick panel, and pull the carpet back to expose the ECU. Unbolt the ECU bracket. Connect the PGM-FI test harness. Then check the system according to the procedure described for the appropriate code(s) listed on the following pages.
 NOTE: Information on this page is for LH and RH models.

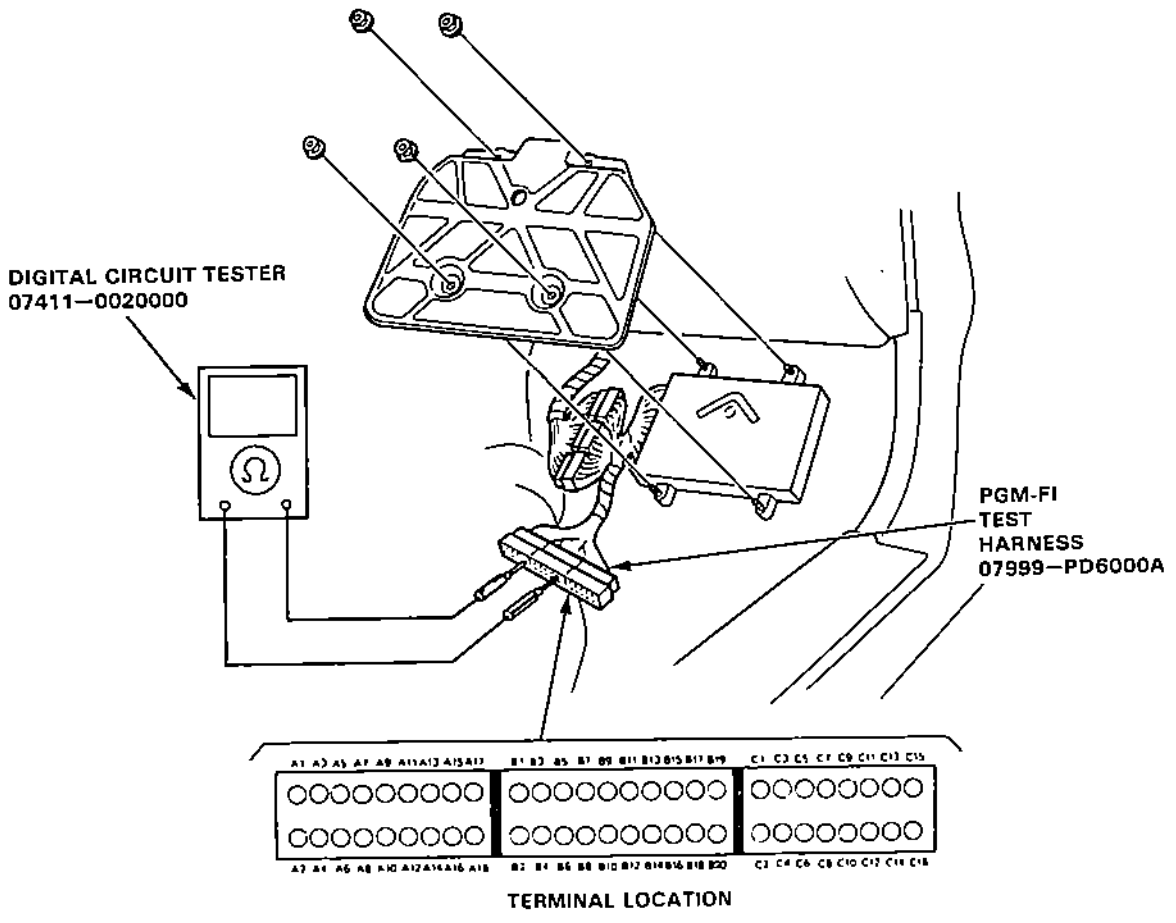

CAUTION:

- Puncturing the insulation on a wire can cause poor or intermittent electrical connections.
- For testing at connectors other than the PGM-FI test harness, bring the tester probe into contact with the terminal from the connector side of wire harness connectors in the engine compartment. For female connectors, just touch lightly with the tester probe and do not insert the probe.

