

# Transmission

## Removal/Installation

### ▲ WARNING

- Make sure jacks and safety stands are placed properly (See section 1), and hoist brackets are attached to correct positions on the engine (See section 5).
- Apply parking brake and block rear wheels, so car will not roll off stands and fall on you while working under it.

**CAUTION:** Use fender covers to avoid damaging painted surfaces.

1. Disconnect the battery negative (-) and positive (+) cables from the battery.
2. Remove the 2 nuts and loosen the bolt located at the side of the battery base.
3. Remove the battery base.
4. Remove the intake hose.
5. Disconnect the transmission ground cable.
6. Disconnect the clutch cable at the release arm and cable stay.
7. Disconnect the back-up light switch connector.
8. Remove the O<sub>2</sub> sensor connector from the holder, then disconnect the O<sub>2</sub> sensor connector.
9. Remove the speed sensor.
10. Disconnect the starter motor cable, then remove the cable holder.
11. Remove the bolts attaching the starter motor, and remove the starter motor.
12. Disconnect the distributor connectors and remove the distributor mount bolts, then remove the distributor from the cylinder head.

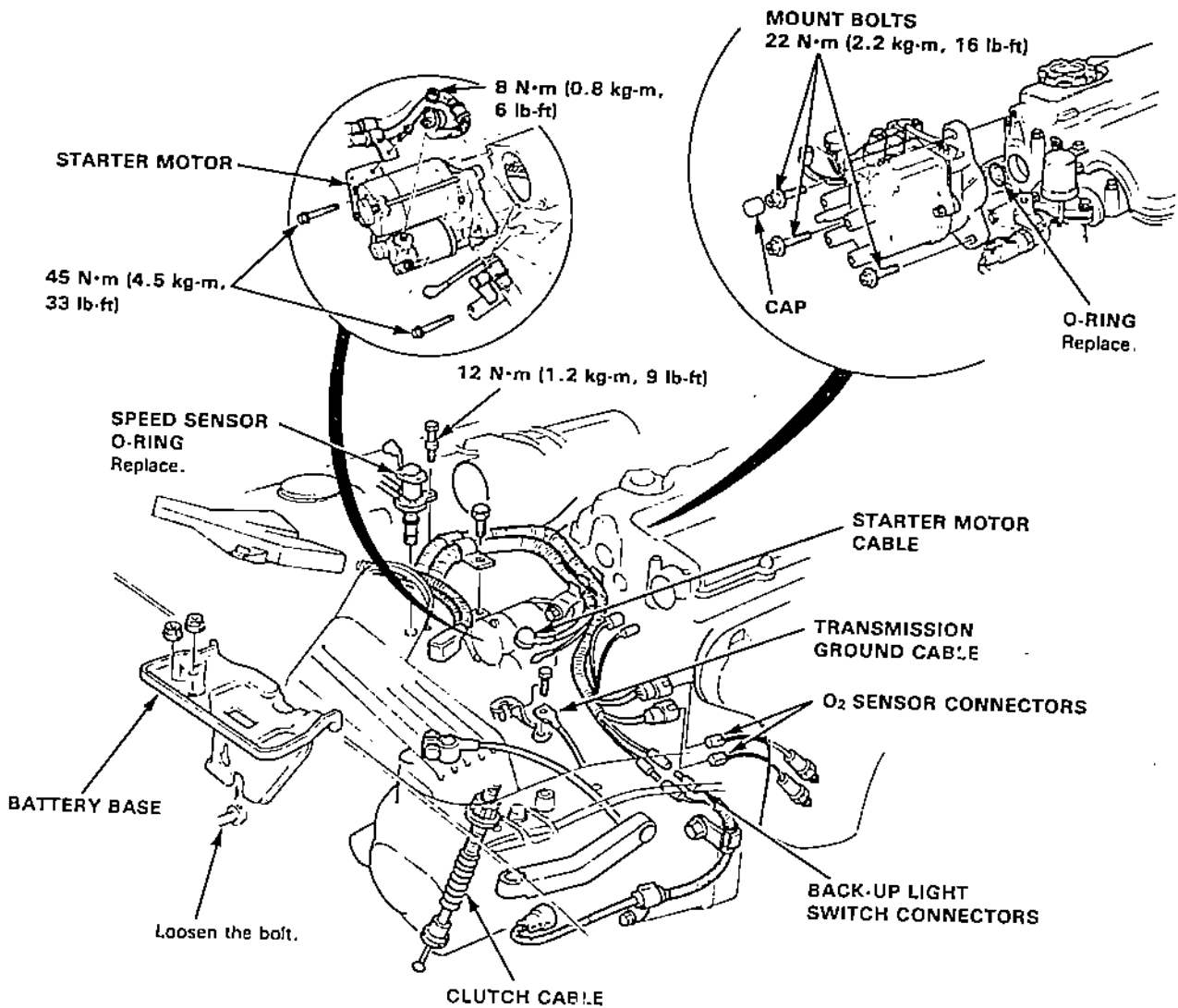



13. Drain transmission oil. Use a socket wrench to remove the drain plug. Remove the oil filler plug to speed draining.  
Reinstall the drain plug with a new washer.
14. Remove the engine splash shield and the right wheel splash shield.
15. Remove the cotter pin and lower arm ball joint nut, separate the ball joint and lower arm (See section 12).
16. Remove the self locknut, and remove the damper fork bolt.
17. Remove the nut and bolts. then remove the right radius rod.

18. Remove the right driveshaft (See section 10).
19. Remove the left driveshaft (See section 10).
20. Remove the intermediate shaft (See section 10).
21. Remove the torque rod and shift rod from the clutch housing.

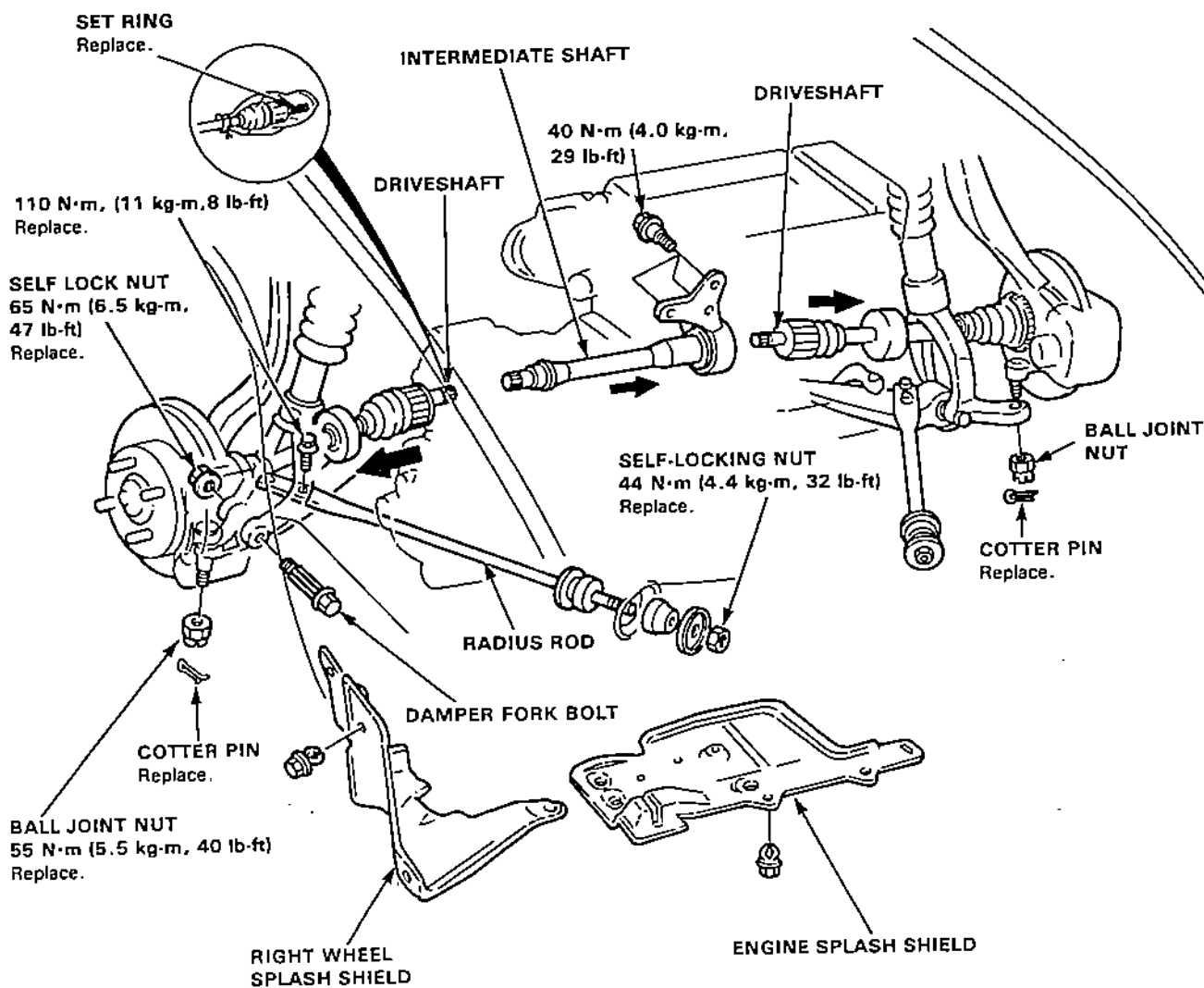

# Transmission

## Removal/Installation

22. Remove the front engine stiffener and rear engine stiffener.
23. Remove the clutch case cover.
24. Remove the 2 transmission mount bolts.

25. Remove the 2 transmission mount bolts from the rear engine mount bracket.
26. Remove the bolt of under the side transmission mount.

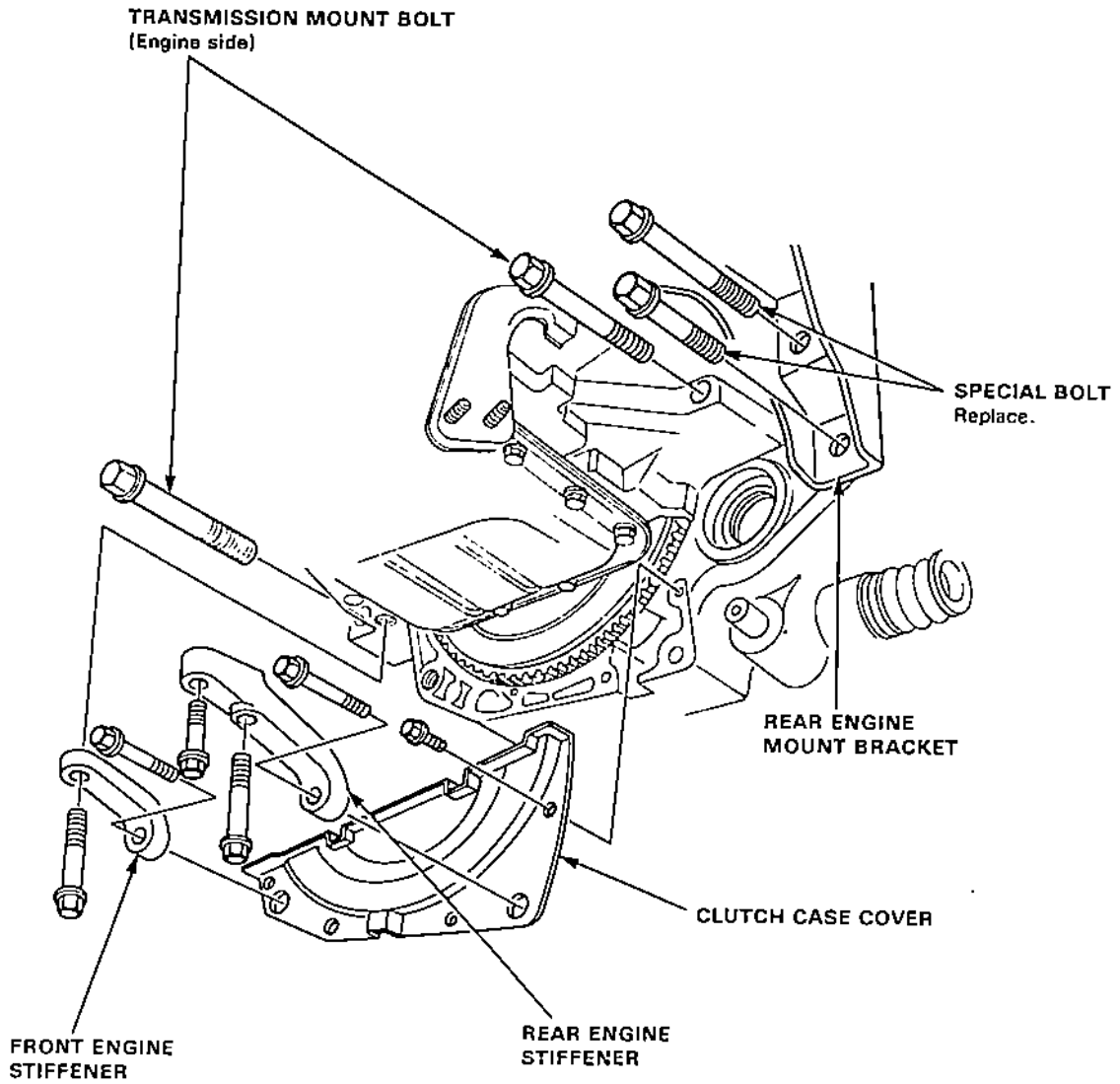



27. Remove the front transmission mount bracket.
28. Install the bolt at the cylinder head and attach a hoist chain to the bolt and the other end to the engine hanger plate, then lift the engine slightly to unload the mounts.
29. Place a jack under the transmission and raise transmission just enough to take the weight off the mounts.
30. Remove the bolts and nut, then remove the side transmission mount.
31. Remove the 3 transmission mount bolts.
32. Pull the transmission away from the engine until it clears the 14 mm dowel pins.
33. Separate the mainshaft from the clutch pressure plate and remove the transmission by lowering the jack.

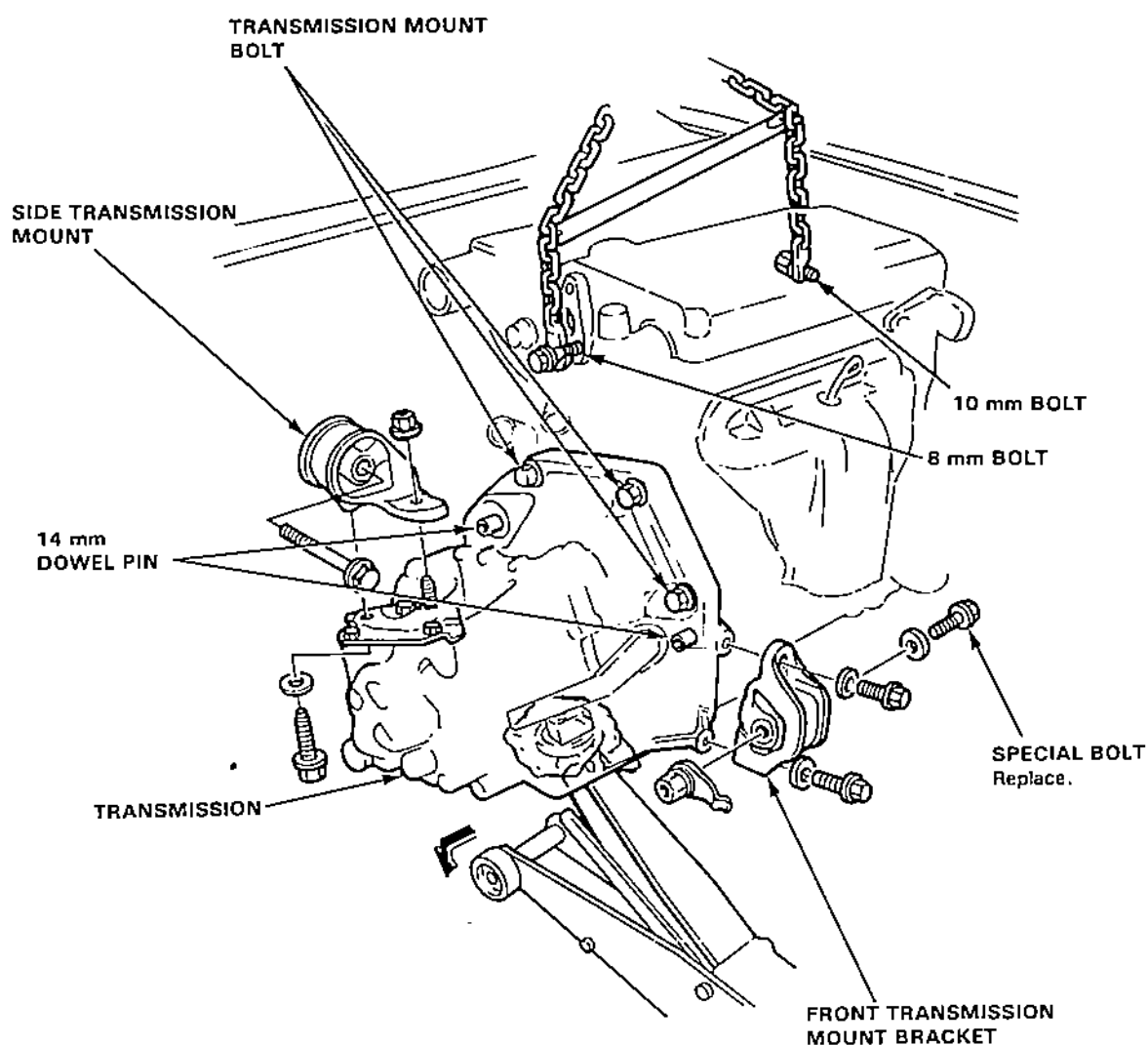

# Transmission

## Removal/Installation

Install the engine in the reverse order of removal.

After the engine is in place:

- Check the transmission oil level.
- Check that the spring clip on the end of each driveshaft clicks into place.

**CAUTION:** Use new spring clips on installation.

- Check the clutch free play.
- Check the ignition timing (See section 16).
- Check the transmission for smooth operation.

