

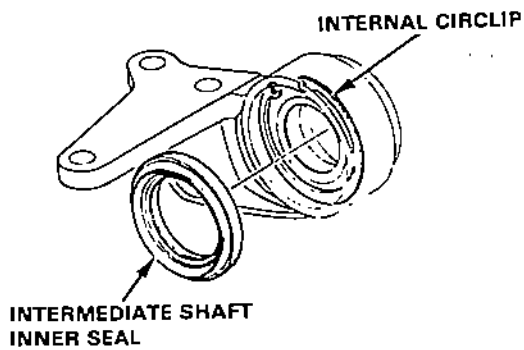

4. Remove the intermediate shaft inner seal.
5. Remove the internal circlip.

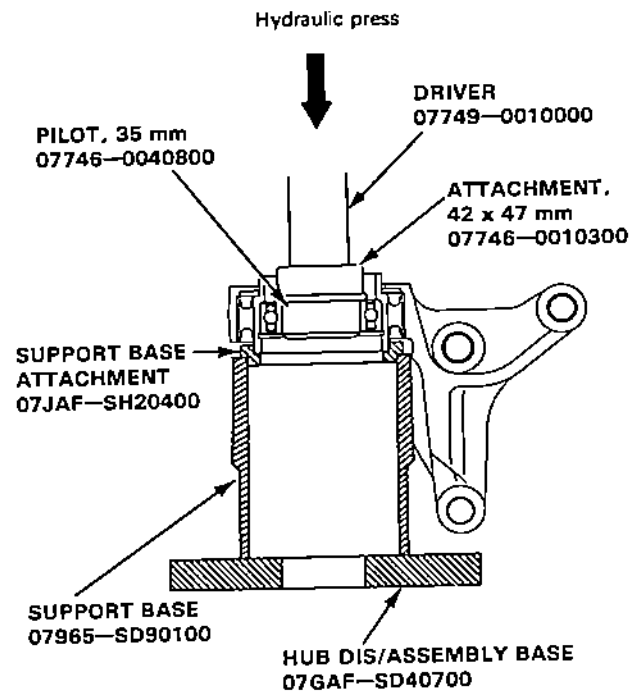

6. Press the intermediate shaft bearing out of the bearing support.



Index/Inspection

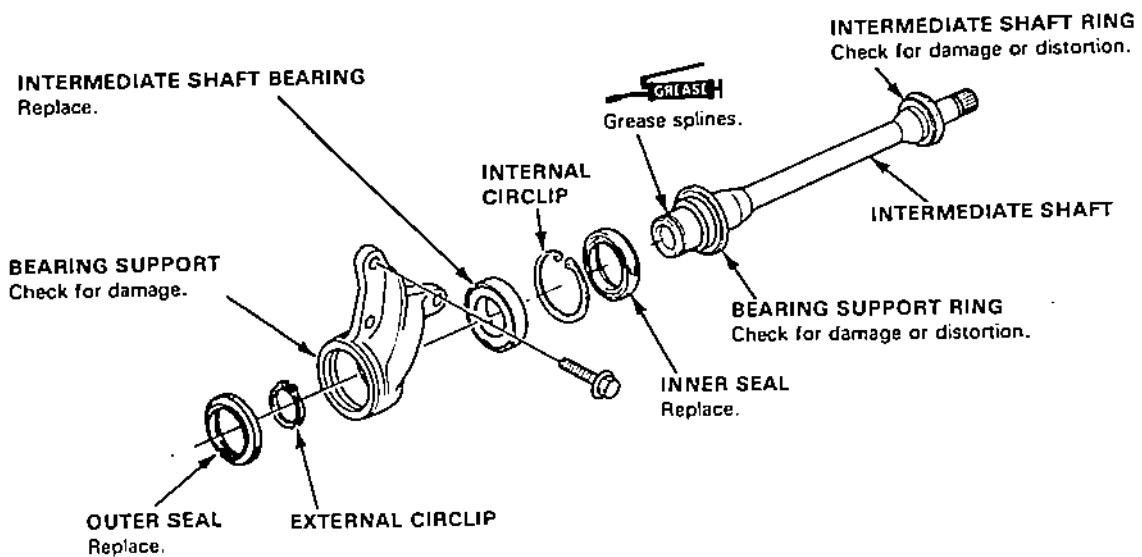

CAUTION: Be careful not to damage the rubber on the bearing support during installation.