

Solenoid

Solenoid Leak Test

1. Connect circuit tester (Ω range) between the BLK and YEL terminals of the accumulator pressure switch connector.
2. Attach the positive (+) lead of a fully charged 12 V battery to the RED/WHT terminal of the power unit motor connector and negative (-) lead to the GRN terminal, and install a switch between as shown.
3. Turn the switch on to allow sufficient pressure to build up within the accumulator and check for continuity with the circuit tester. If the circuit tester shows continuity (pressure switch turned on), run the power unit for 4 seconds more, then turn the switch off.

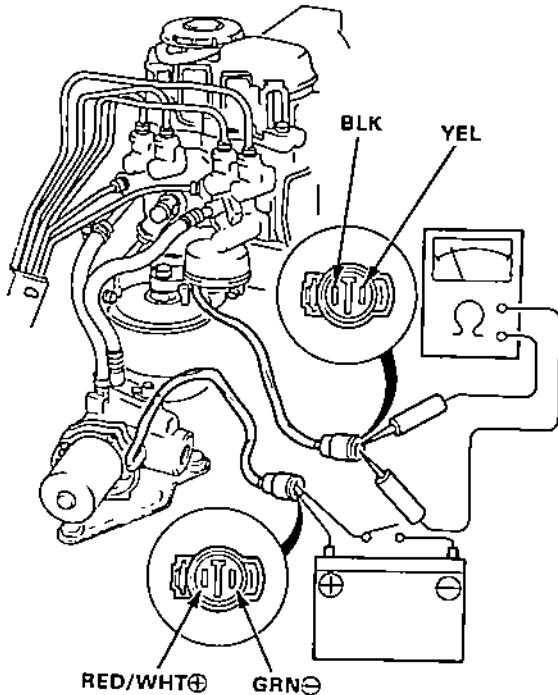

Check for continuity 1 minute after switch was turned off.

No continuity.....Leaky solenoid (if the pipe joint is tight) or faulty divider O-ring

4. Apply 12 V across the BLK and RED terminals of the solenoid connector momentarily.

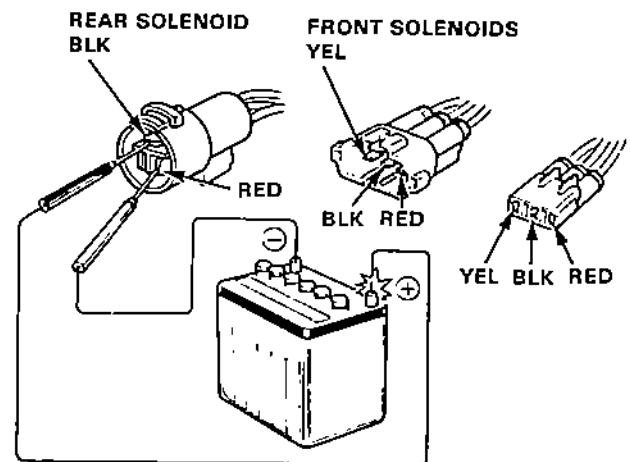

NOTE: Modulator reservoir may overflow.

- Check if the solenoid hisses or squeaks. Replace the modulator if the solenoid hisses or squeaks.
- Make sure that the solenoid does not hiss or squeak after it has clicked into position. Replace the modulator if the solenoid hisses or squeaks.
- Check the pressure switch for continuity within one minute. It is normal if there is continuity. If there is no continuity, solenoid is faulty and must be replaced.

