

Piston

Removal

1. Remove the modulator heads.

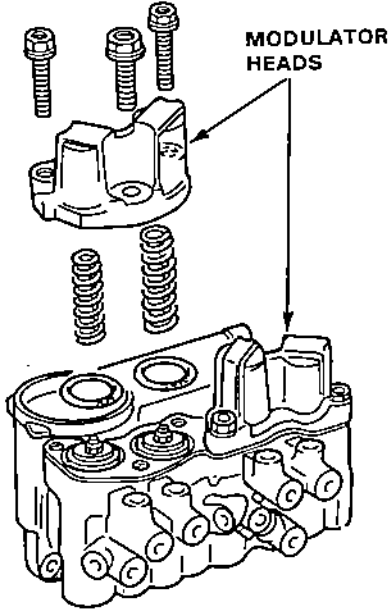

2. Insert the driver into the spring, pry off the piston assembly until it lifts up slightly and pull out the lock nut with a pair of pliers.

CAUTION:

- Set the washer between the driver and modulator body to prevent damage to the body.
- Be careful not to damage the piston sleeve.

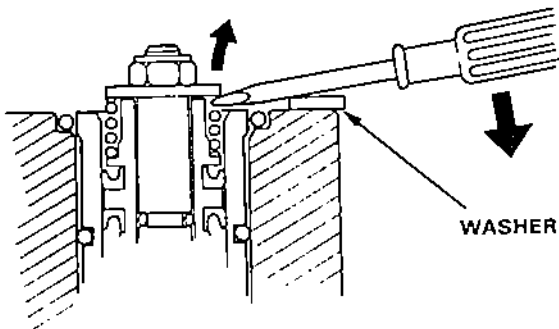

Installation

1. Apply rubber grease to the shaded sections of the piston assembly, shown in the drawing below.

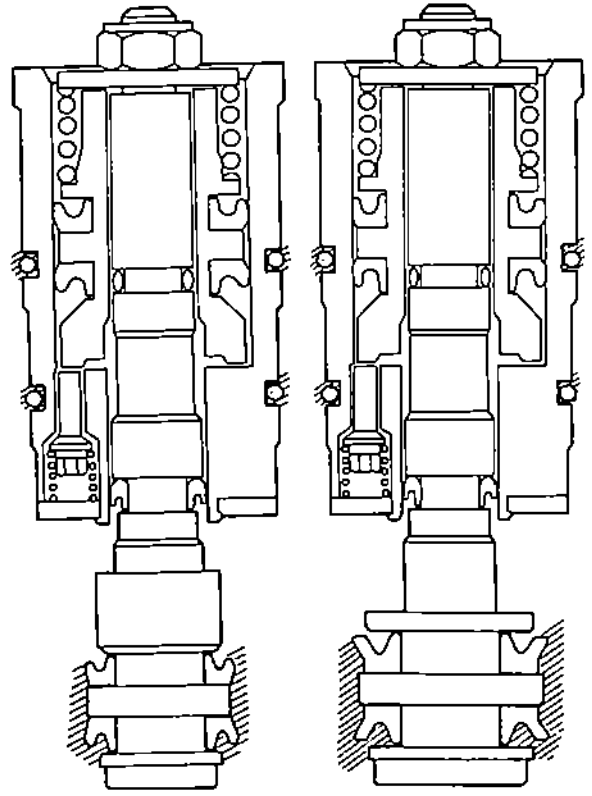

2. Adjust so that the brake fluid flows into the piston mounting hole in the modulator body.

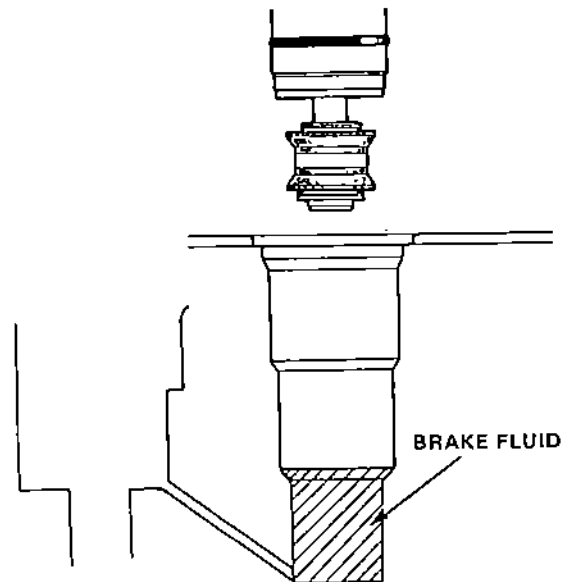

(cont'd)

Piston

Installation (cont'd)

3. Set the piston assembly in the piston mounting hole in the modulator body and push down on the piston.
4. Push on the piston about 5 times until no bubbles come out of the solenoid side.

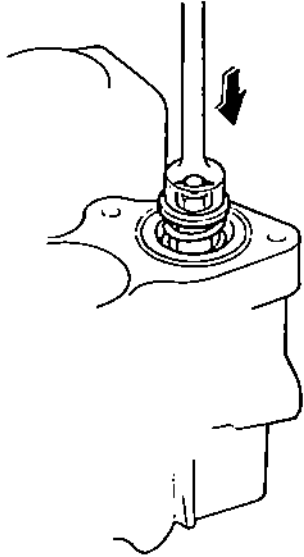

5. Install the modulator springs.
6. Install the solenoid heads with care not to pinch the O-rings.

