

Ground Distribution

Circuit Identification

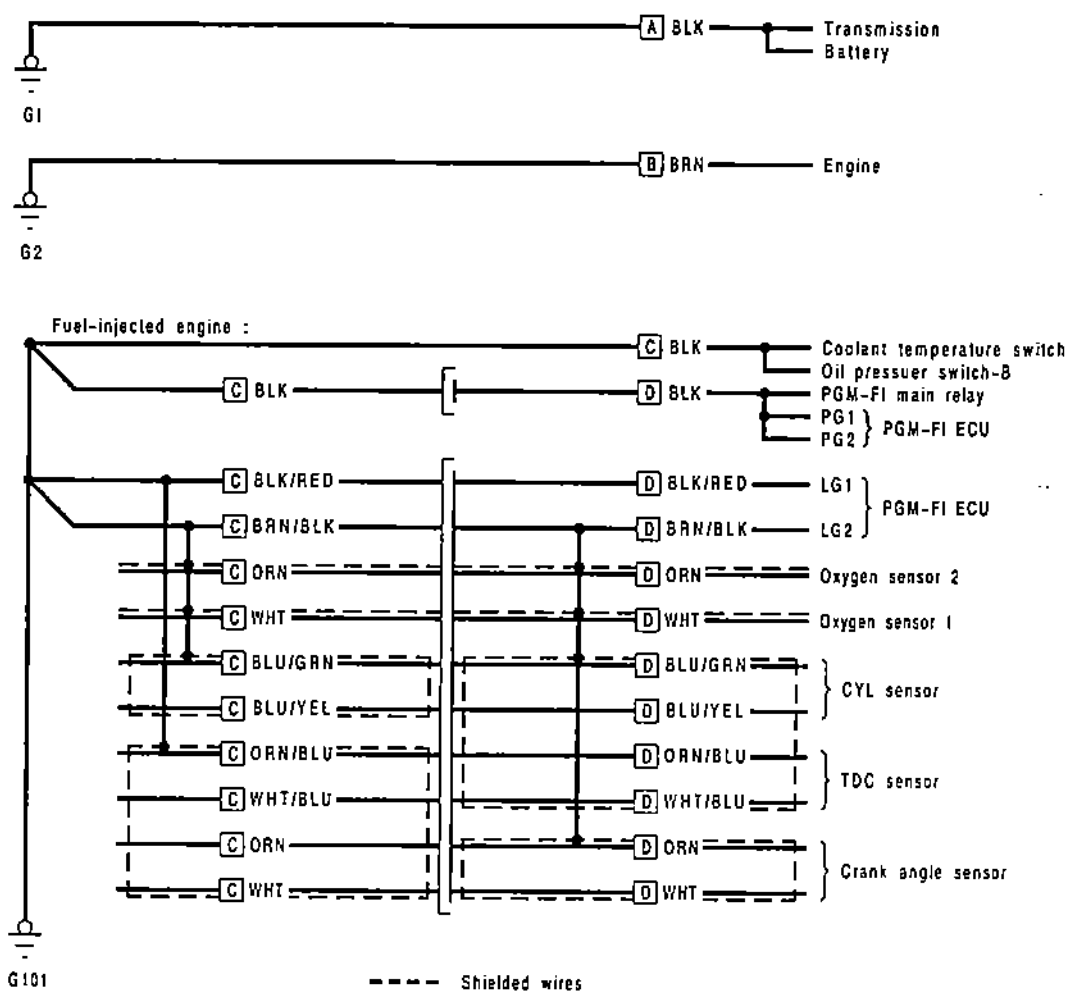

- [A] : Battery ground wire
- [B] : Engine ground wire
- [C] : Engine wire harness
- [D] : Main wire harness



RHD :

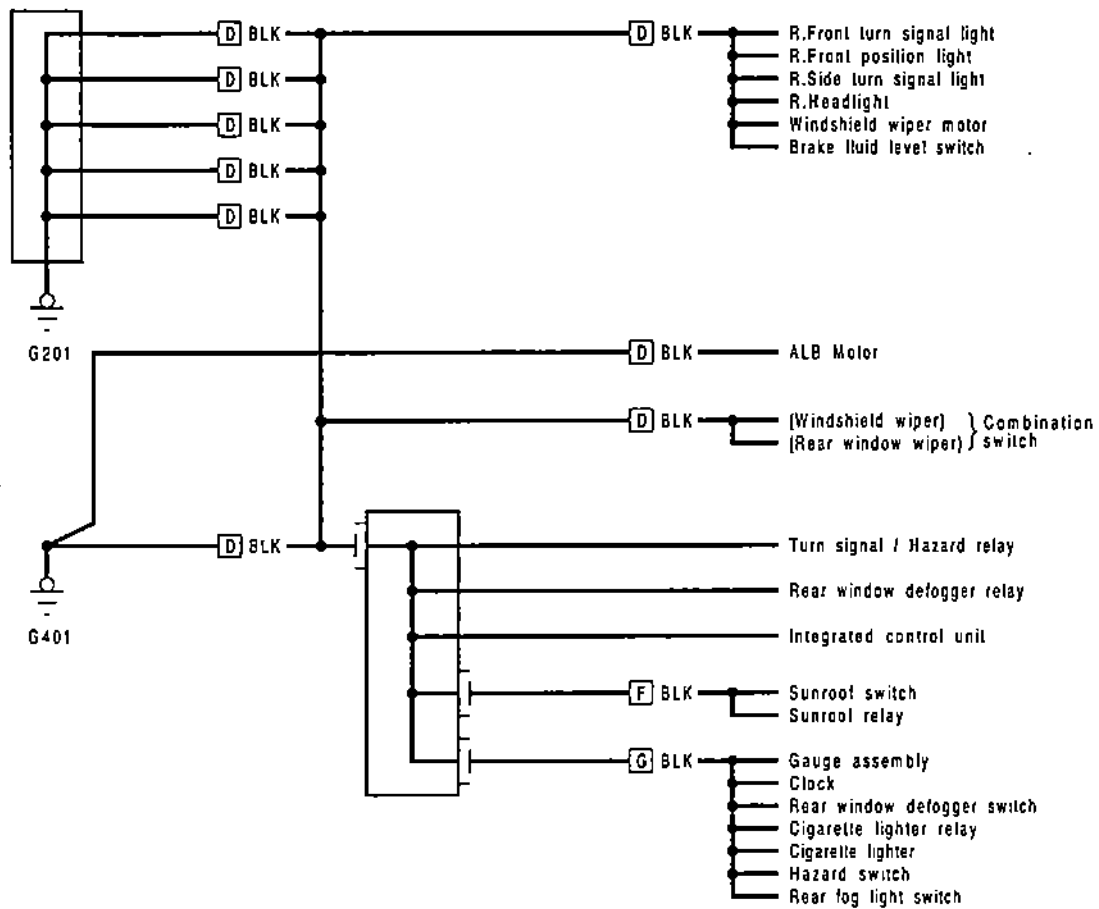

- G** : Engine wire harness
- D** : Main wire harness
- E** : Front Passenger's door wire harness
- F** : Roof wires
- G** : Dashboard wire harness
- J** : Rear wire harness

(cont'd)

Ground Distribution

Circuit Identification (cont'd)

RHD :

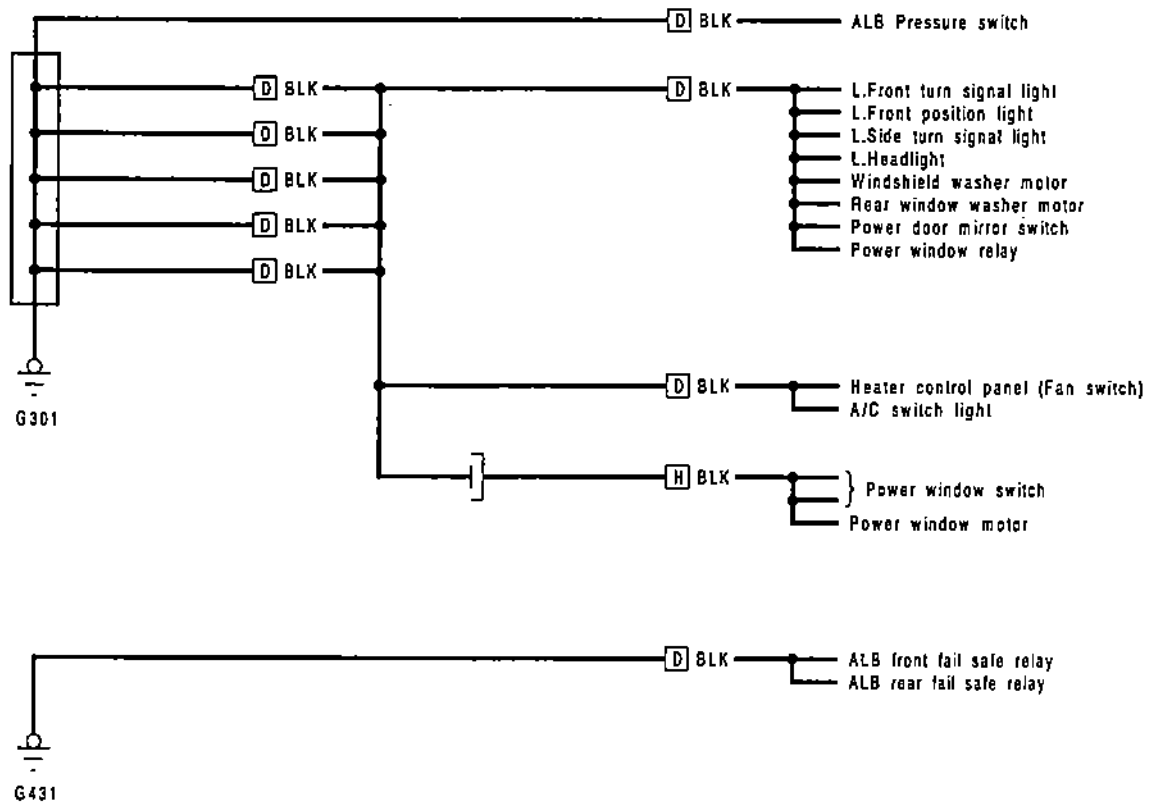

(Located left side, on the kick panel)

- D : Main wire harness
- H : Driver's door wire harness



LHD :

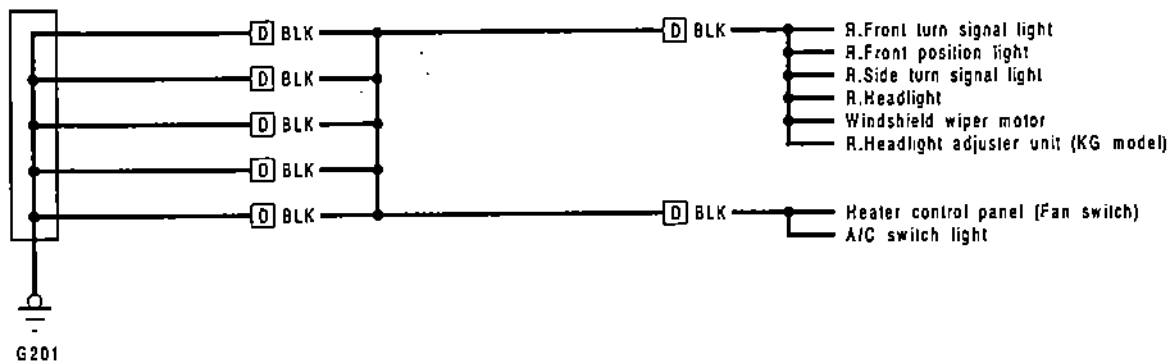

D : Main wire harness

(cont'd)

Ground Distribution

Circuit Identification (cont'd)

LHD :

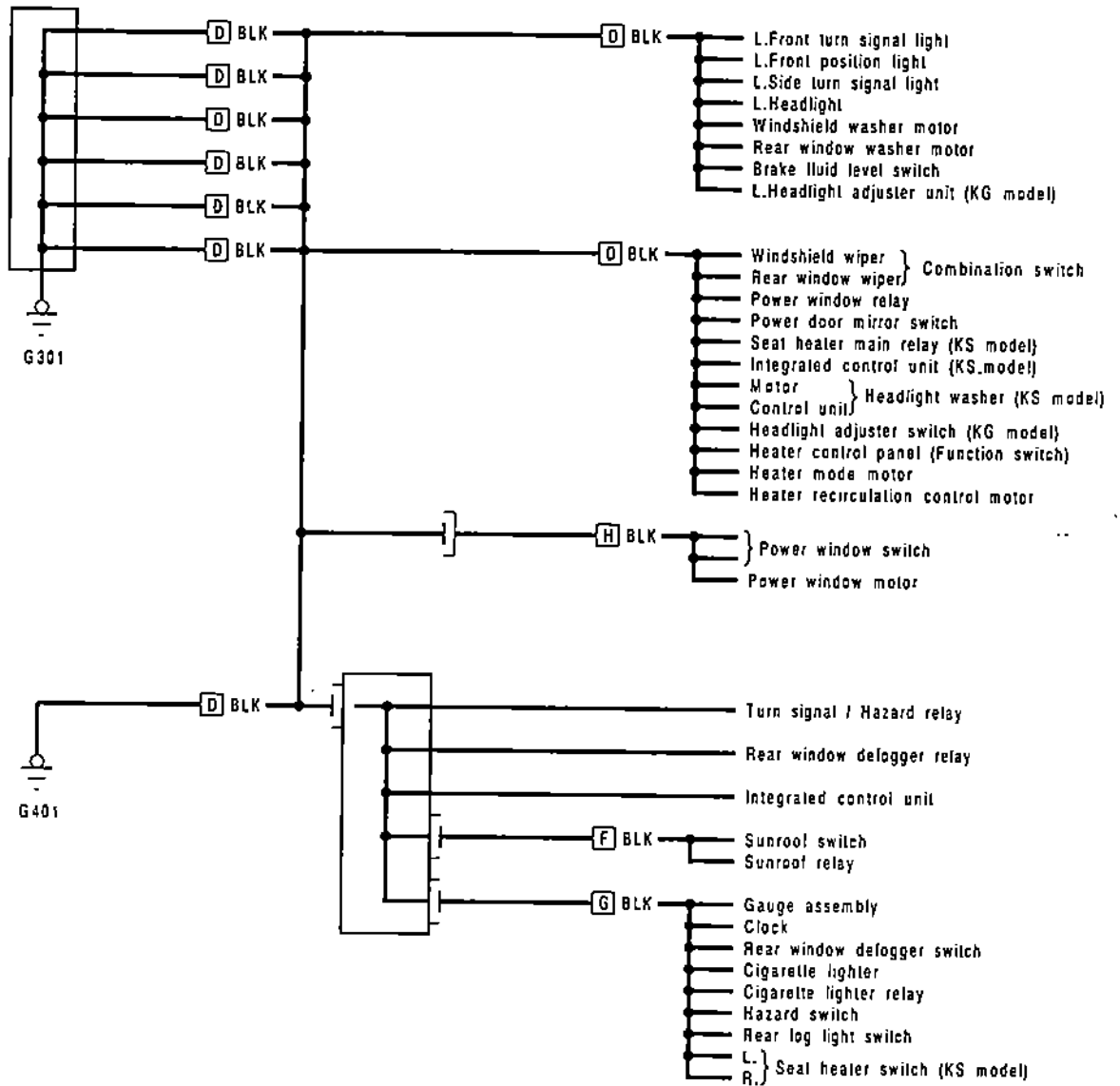

- D** : Main wire harness
- F** : Roof wires
- G** : Dashboard wire harness
- H** : Driver's door wire harness

