

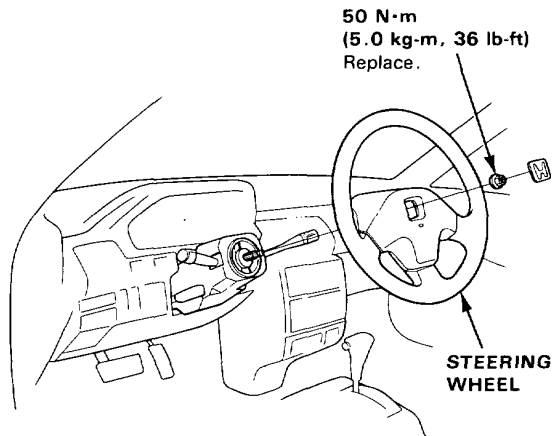

# Steering Column

## Removal

1. Remove the center pad.
2. Remove the steering shaft nut.
3. Remove the steering wheel by rocking it slightly from side-to-side as you pull steadily with both hands.



4. Remove the cover panel.

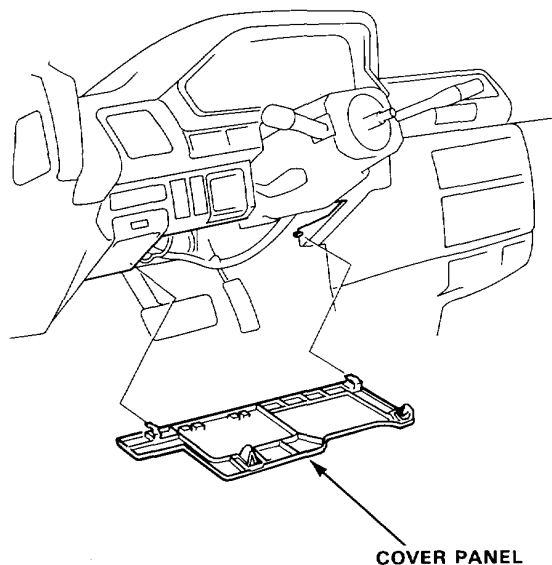

5. Remove the steering joint cover.

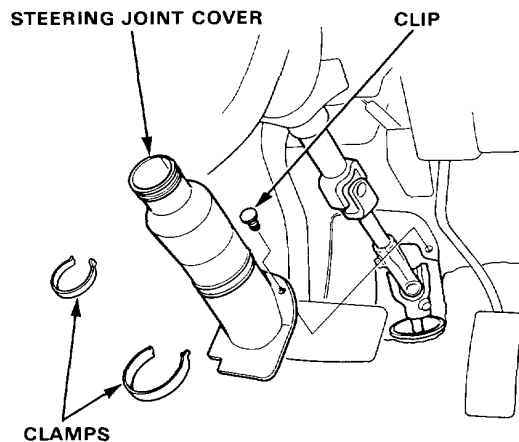

6. Remove the lower steering joint bolt.

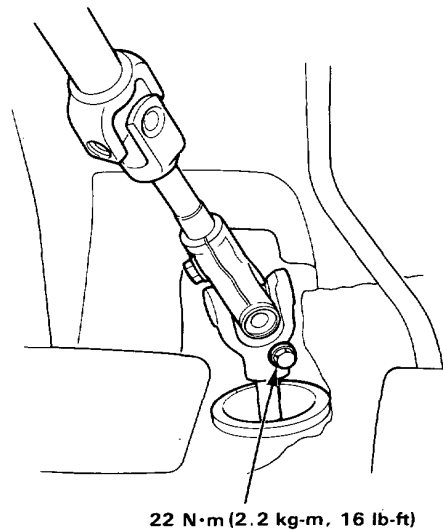

(cont'd)

# Steering Column

## Removal (cont'd)

7. Remove the upper and lower column covers.

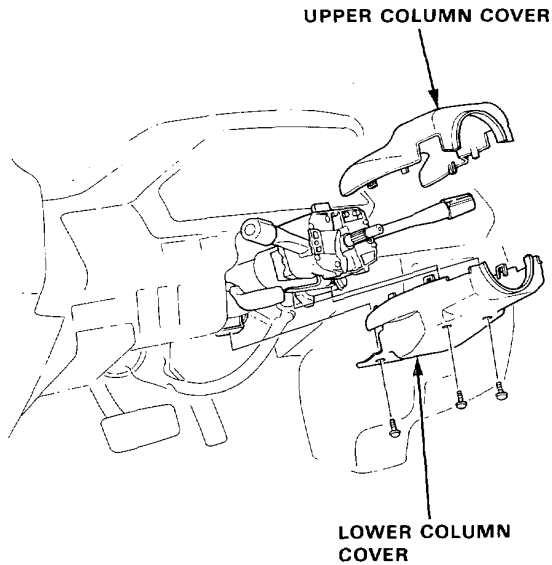

8. Disconnect each wire coupler from the combination switch.
9. Remove the turn signal cancelling sleeve and combination switch assembly.

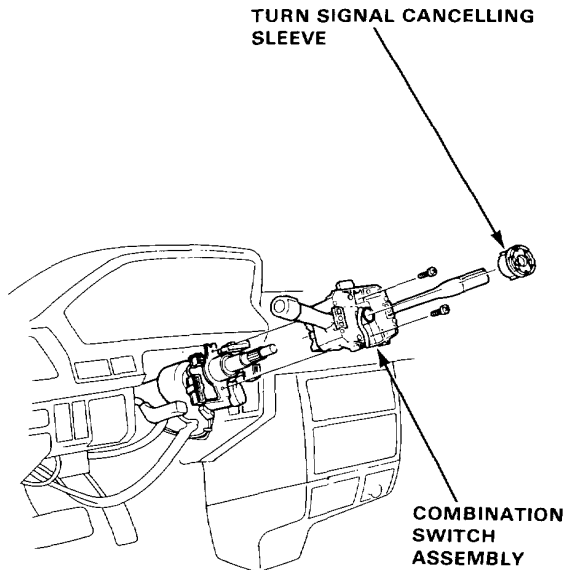

10. Remove the lower column bracket.

11. Remove the nuts attaching the bending plate guide and bending plate.

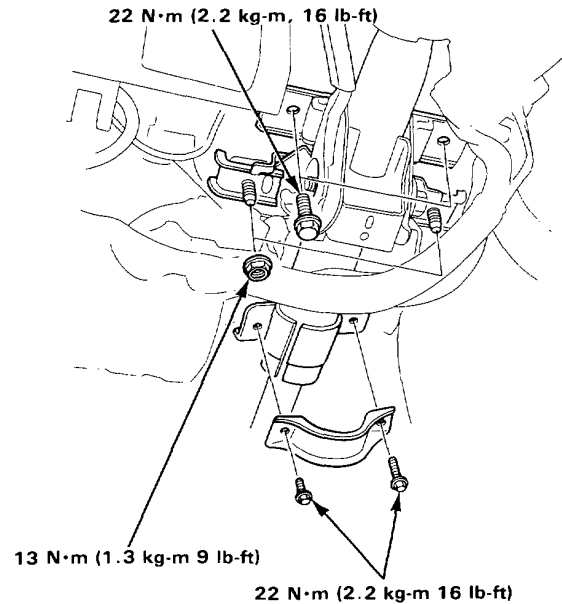

12. Disconnect each wire coupler from the fuse box at under-dash left side.

13. Remove the steering column assembly.

