

Steering Column

Reassembly

1. Install the circlip on the steering shaft.

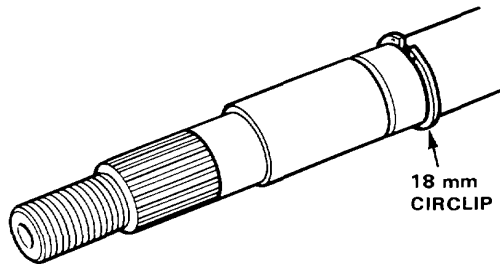

2. Install the retaining collar on the steering column aligning the hole in the column with tab on the retaining collar.

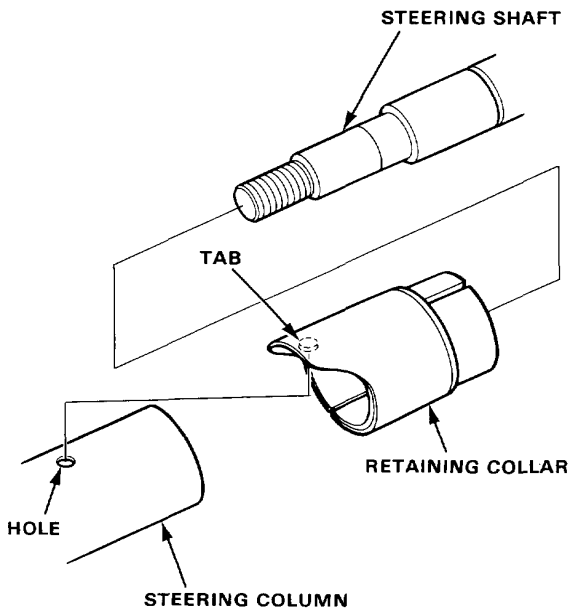

3. Insert the steering shaft into the steering column from the bottom.
4. Install the 24×18 mm spring washer and steering washer on the steering shaft and secure with the 18 mm snap ring.

NOTE: Install the spring washer as shown.

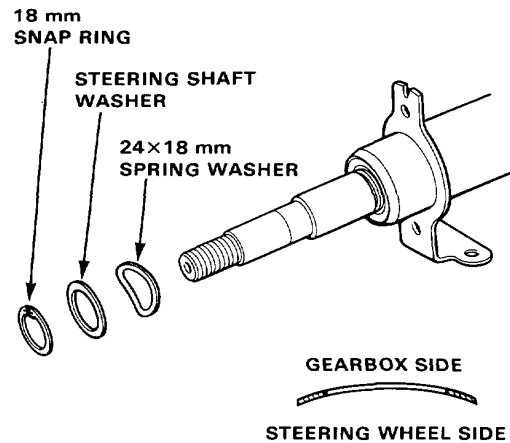

5. Position the bending plate guide on the steering column.
6. Loosely install the tilt lever, tilt lever spring, washers, and the bending plate guide on the steering column with the tilt lock bolt.
7. Install the column hanger springs between the bending plate base and steering column.

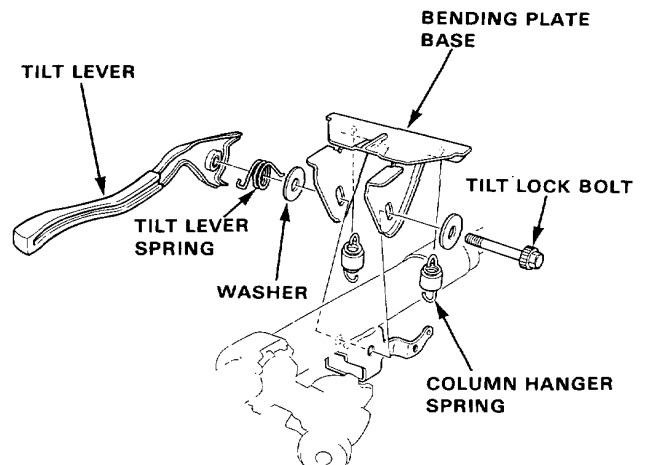



8. Tighten the tilt lock bolt to $20\text{N}\cdot\text{m}$ ($2.0\text{ kg}\cdot\text{m}$ $14\text{lb}\cdot\text{ft}$), then position the tilt lock plate on the splined portion of the tilt lock bolt and loosely attach with the tilt adjusting bolt.

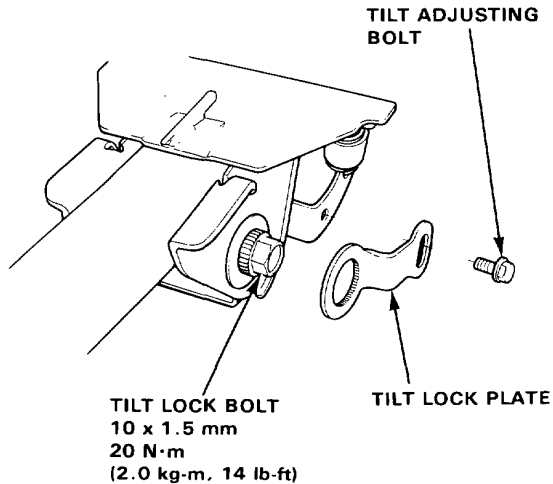

9. Attach a spring scale 10mm (3.937in) from the end of the knob. Measure the force required to move the lever.

Preload: 80N(8.0kg, 18lbs)

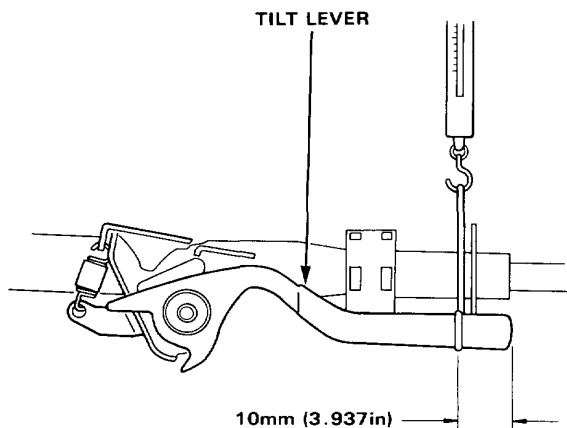

10. If the force measured is not within the specification, remove the tilt lock plate then reset it in the position where the correct force can be obtained.

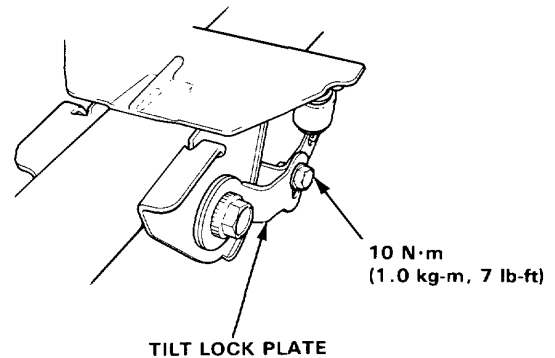

11. Tighten the tilt adjusting bolt.
12. Install the upper column holder and bending plate with the bending plate spring on the bending plate base.

NOTE: Install the bending plate with arrow mark facing the steering gearbox.

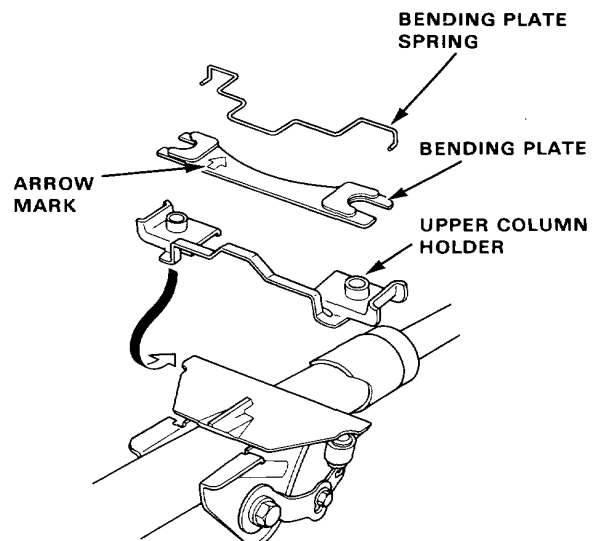

(cont'd)

Steering Column

Reassembly (cont'd)

- Slip the upper end of the steering joint onto the pinion shaft (line up the bolt hole with the groove around the shaft) and loosely install the top bolt.

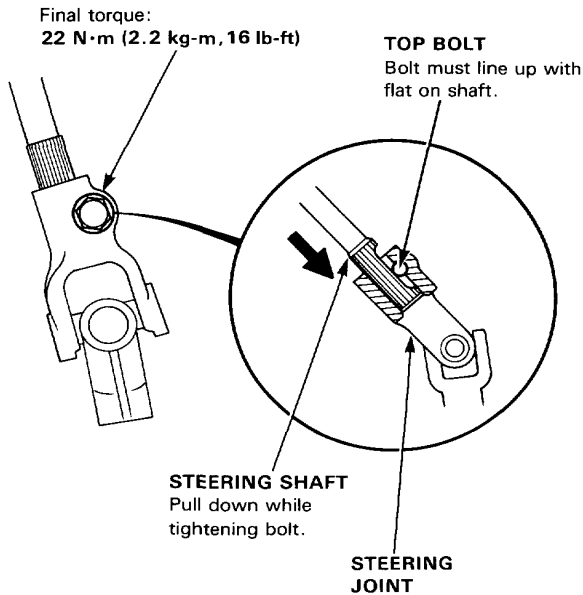

Installation

- Set the guide rails in the bending plate guide and install the bending plate guide on the bending plate base.
NOTE: Install the bending plate guide with its arrow mark toward the gearbox.

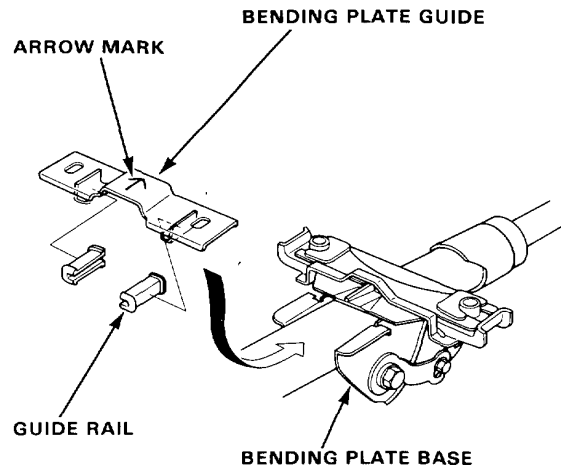

- Loosely install the steering column assembly with the nuts, bolts, and lower column bracket.

Tighten to these torques in step 7, page 11-17:
22N·m (2.2 kg-m 16 lb-ft)

