

Column

Reassembly (cont'd)

13. Slip the upper end of the steering joint onto the pinion shaft (line up the bolt hole with the groove around the shaft) and loosely install the top bolt.

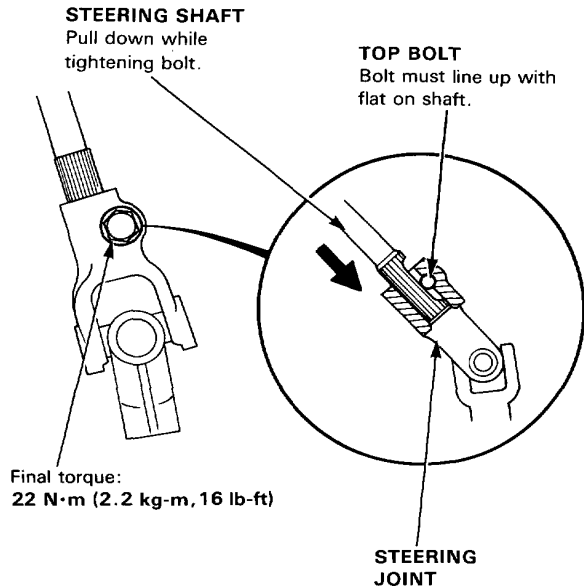

Installation

1. Set the guide rails in the bending plate guide and install the bending plate guide on the bending plate base.

NOTE: Install the bending plate guide with its arrow mark toward the gearbox.

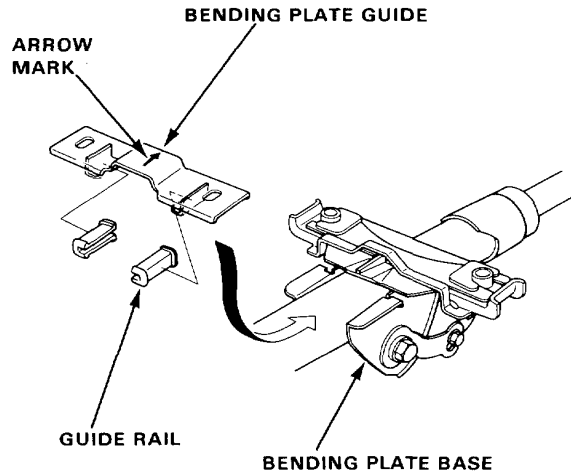

2. Loosely install the steering column assembly with the nuts, bolts and lower column bracket.

Tighten to these torques in step 7, page 11—33:
22 N·m (2.2 kg-m, 16 lb-ft)

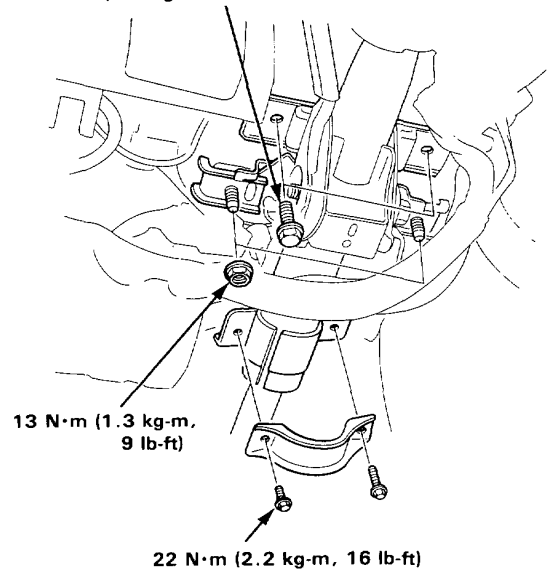



3. Connect each wire coupler to the fuse box at the under dash left side.

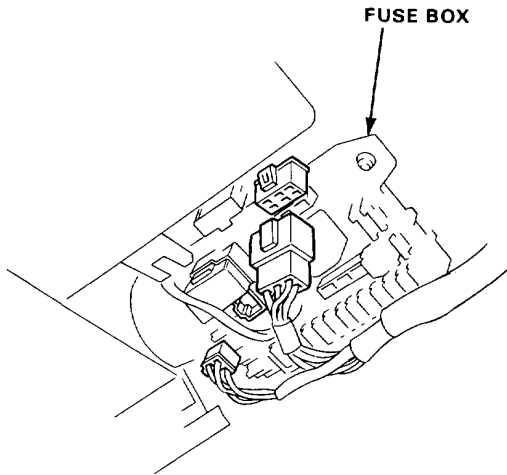

4. Install the combination switch assembly and turn signal cancelling sleeve.
5. Connect each wire coupler to the combination switch.

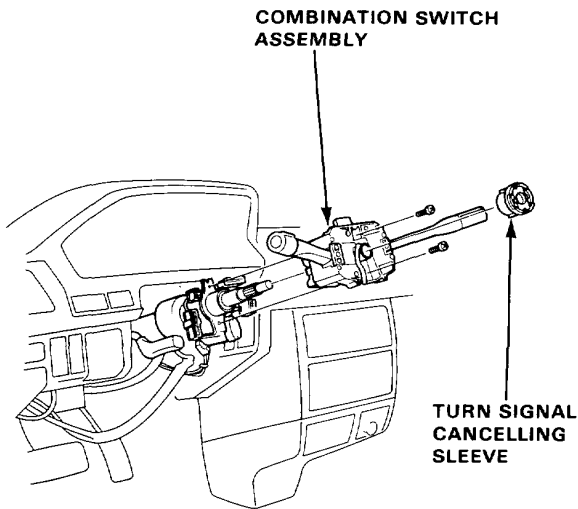

6. Loosely install the steering joint on the steering gearbox pinion.
NOTE: Be sure that the lower bolt is securely in the groove in the steering gearbox pinion.

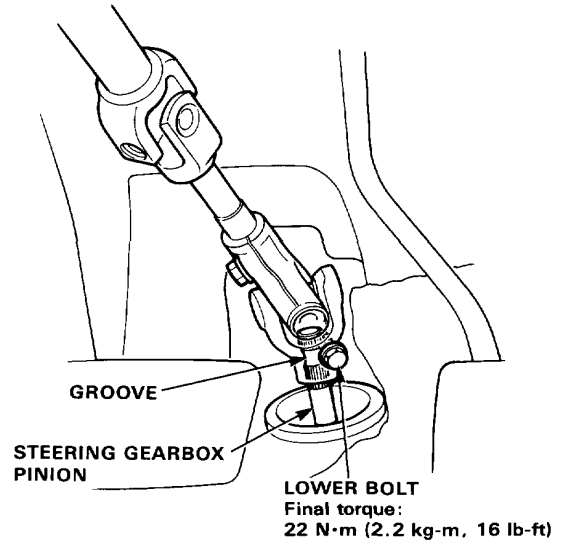

7. Tighten the steering column mounting bolts, nuts and bracket loosely installed in step 2.
8. Tighten the and upper steering joint lower and top bolts.
9. Install the upper column cover and lower column cover.

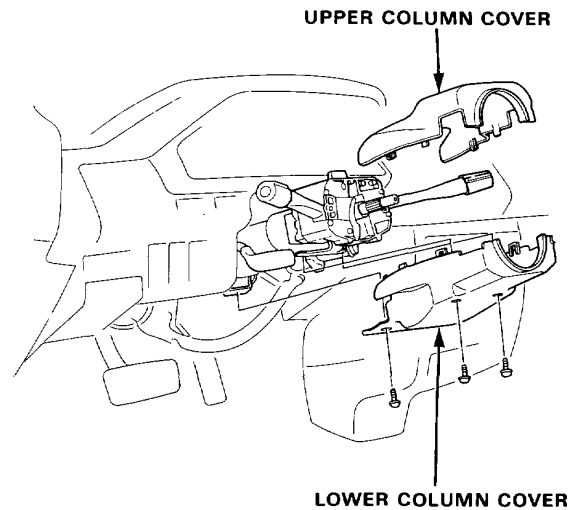

(cont'd)

Column

Installation (cont'd)

10. Install the steering joint cover with the clamps and clip.

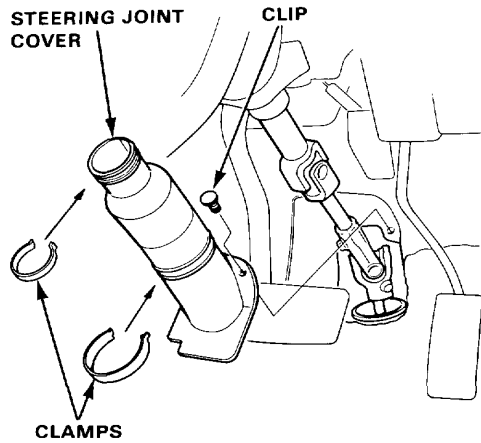

11. Install the cover panel.

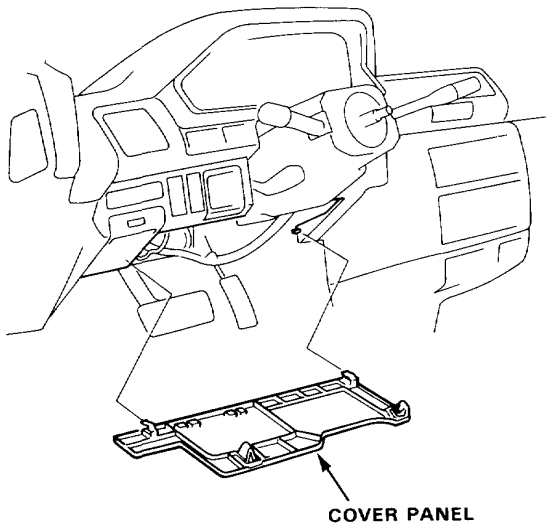

12. Install the steering wheel in a straight ahead position.
13. Tighten the steering wheel mount nut and torque to 50 N·m (5.0 kg-m, 36 lb-ft).
14. Check that the horn works properly, then install the center pad.

