

Master Cylinder

Reassembly

CAUTION:

- Make sure all parts are clean before reassembly.
 - Use only new replacement parts.
 - Use only clean brake fluid.
 - Do not allow dirt or other foreign matter to contaminate the brake fluid.
 - Do not mix different brands of brake fluid.
 - Avoid spilling brake fluid on painted, plastic or rubber surfaces as it can damage the finish.
- Wash spilled brake fluid off immediately with clean water.

1. Lubricate new piston assemblies with brake fluid, then fit them together.

PRIMARY PISTON ASSEMBLY

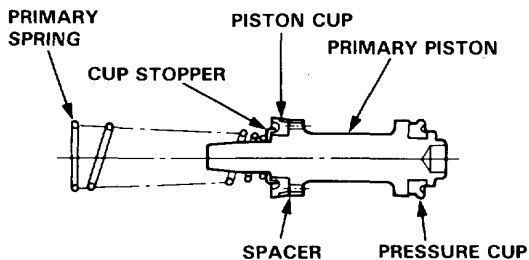

SECONDARY PISTON ASSEMBLY

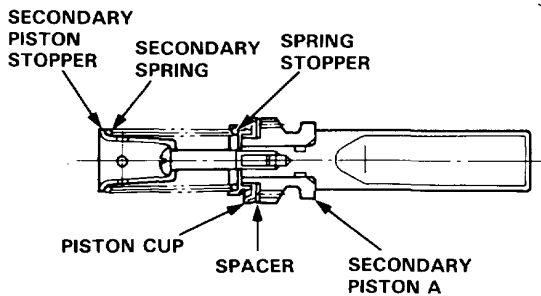

PISTON GUIDE ASSEMBLY

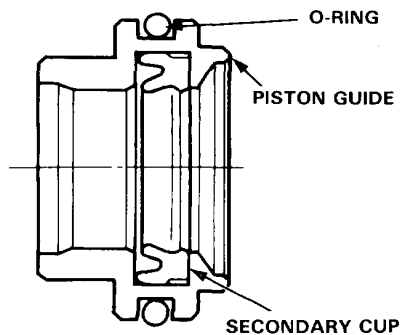

2. Install the piston assemblies in the master cylinder.

NOTE: To ease assembly, rotate the pistons while inserting.

3. Install the stop bolt and new sealing washer while pushing in the secondary piston assembly, then tighten the stop bolt.

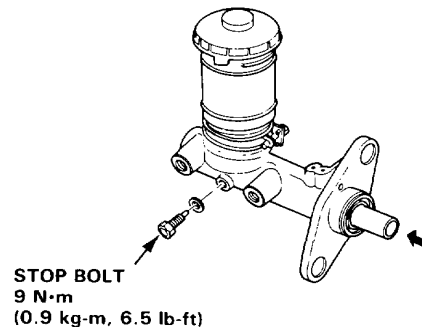

4. Install the snap ring while pushing in the secondary piston assembly.

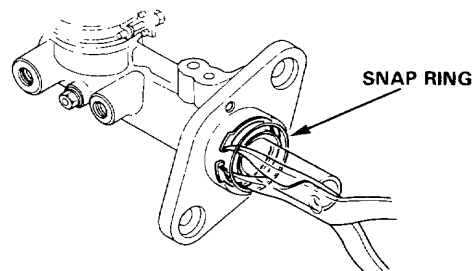

5. Install a new rod seal.

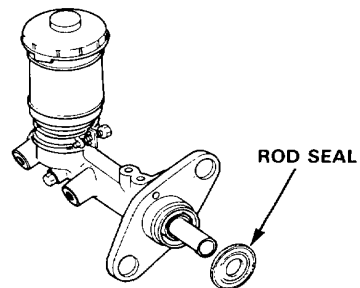

CAUTION: When connecting the brake pipes, make sure that there is no interference between the brake pipes and other parts.