

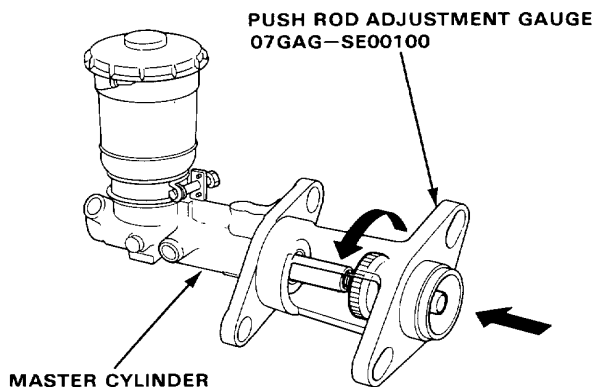

## Pushrod Clearance Adjustment

**NOTE:** Master cylinder pushrod-to-piston clearance must be checked and adjustments made, if necessary, before installing master cylinder.

1. Using the Push Rod Adjustment Gauge, adjust bolt so the top of it is flush with end of master cylinder piston.



2. Install the master cylinder rod seal between the push rod adjustment gauge and brake booster.
3. Without disturbing the adjusting bolt's position, put the gauge upside down on the booster.
4. Install the master cylinder nuts and tighten to the specified torque.
5. Connect the booster in-line with a vacuum gauge to the booster's apply a 500 mm Hg (20 in Hg) vacuum and hold.
6. With a feeler gauge, measure the clearance between the gauge body and the adjusting nut.

**CLEARANCE:** 0–0.4 mm (0–0.016 in)

- Booster out of car.

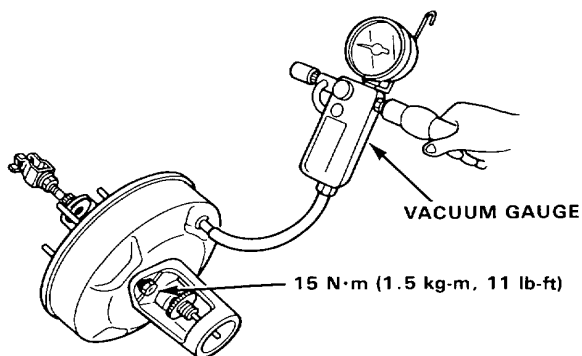

- Inspection with the booster attached to the car.

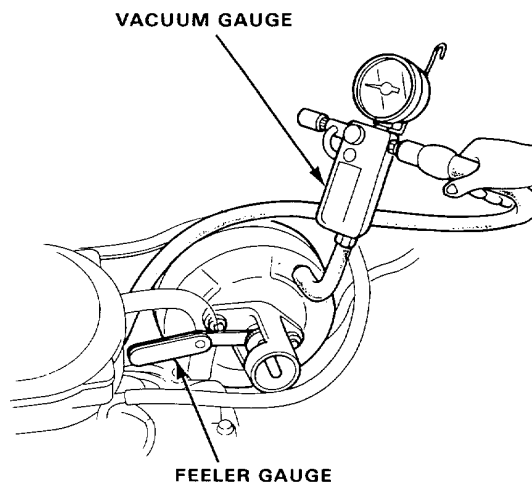

7. If clearance is incorrect, loosen the star locknut and turn the adjuster in or out to adjust. Hold the clevis while adjusting.
8. Tighten the star locknut securely.

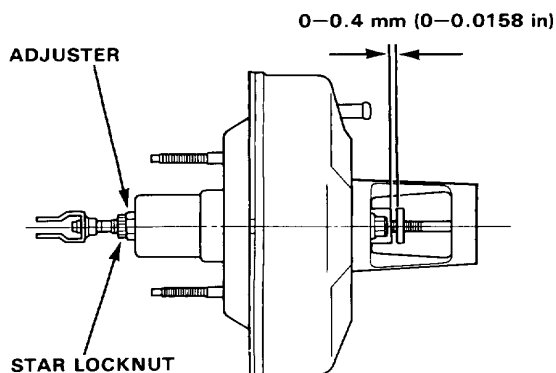

**NOTE:** If the clearance between the gauge body and adjusting nut is 0 mm, the push rod-to-piston clearance is 0.04 mm. If the clearance between the gauge body and adjusting nut is 0.4 mm, the push rod-to-piston clearance is 0 mm.

(cont'd)

# Brake Booster

## Pushrod Clearance Adjustment (cont'd)

9. After adjustment, loosen the clevis end pushrod lock-nut and turn the pushrod to obtain the correct pedal height.

### **PEDAL HEIGHT FROM FLOOR:**

**LHD: 153 mm (6.02 in)**

**RHD: 161 mm (6.34 in)**

**(with floor mat removed)**

**The pedal should have**

**1—5 mm free play.**

10. Adjust the brake light switch (page 13-4).