

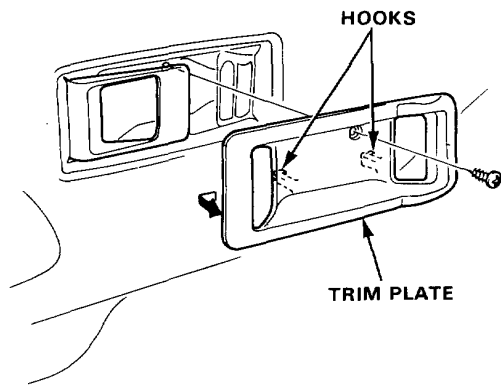

# Disassembly

1. Remove the trim plate screw, then carefully remove the trim plate.



2. Remove the power window switch, if equipped, from the trim plate by removing the 4 screws.

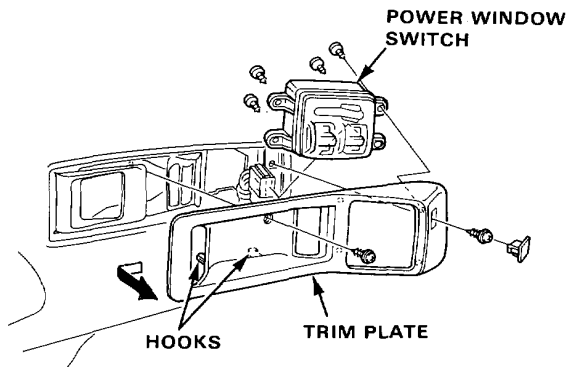

3. If applicable, remove the regulator handle by pulling the clip out with a wire hook.

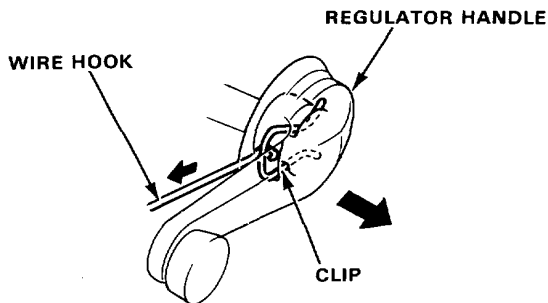

4. Remove the screw and carefully pry up the armrest pocket. Remove the screws, then remove the speaker cover. Remove the screws and clips (see door panel release tool) attaching the door panel. Remove the door panel by pulling it upward.

**NOTE** ● The speaker cover has 6 hooks on its back side.

- Remove the panel with as little bending as possible to avoid creasing or breaking it.

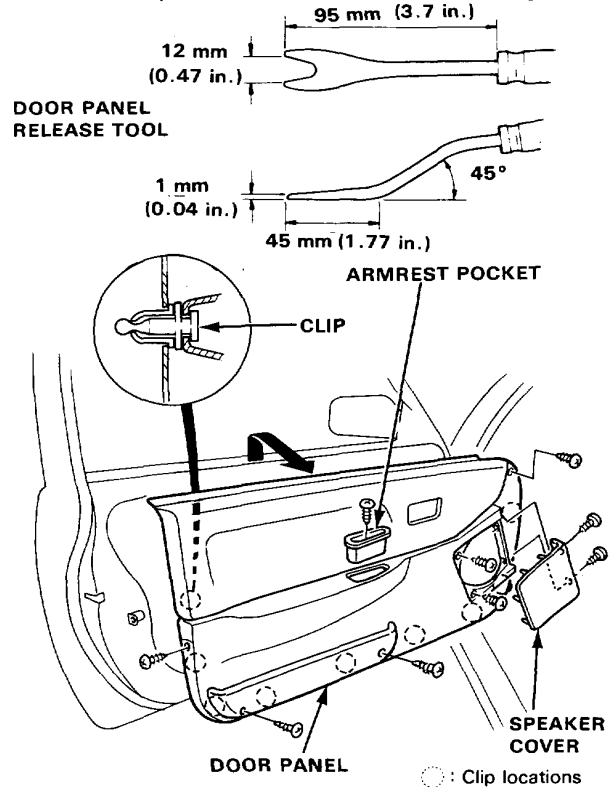

5. Remove the screws, then remove the speaker and door panel bracket.
6. Carefully remove the plastic cover.

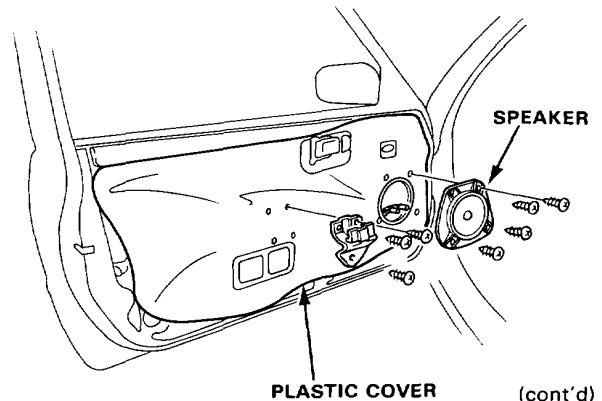

# Doors

## Disassembly (cont'd)

7. Raise the window fully.
8. Remove the 3 screws, disconnect the latch rods, then remove the inside door handle.

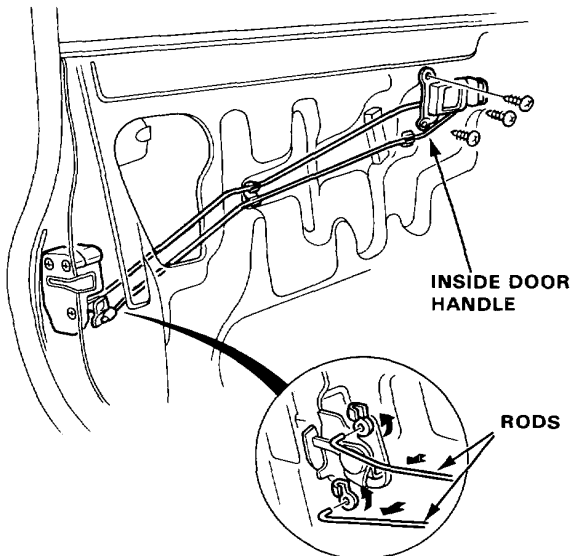

9. Pull out the retainer clip, take out the lock cylinder, then disconnect the lock rod.

NOTE: Use protective tape around the edge of the door handle to prevent scratching the paint.

10. Remove the mounting bolts for the outside door handle.

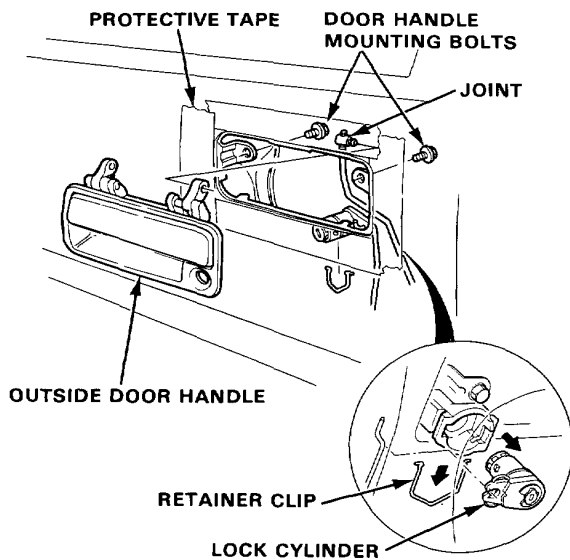

11. Pull the outside door handle out, and pry the joint off the handle with a flat-tip screwdriver. Remove the handle from the rod.

12. Remove the screws, take the door latch off the door, then push the door latch and rod inside the door.

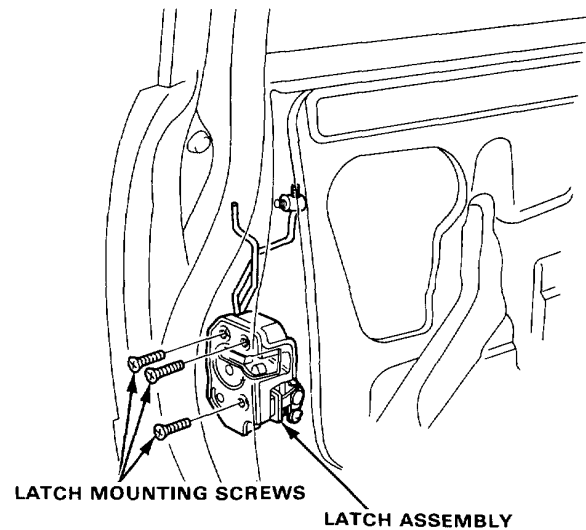

13. Lower the window fully.
14. Remove the door mirror (page 14-8, 9).
15. Remove the screw and detach the clips, then remove the outer molding.

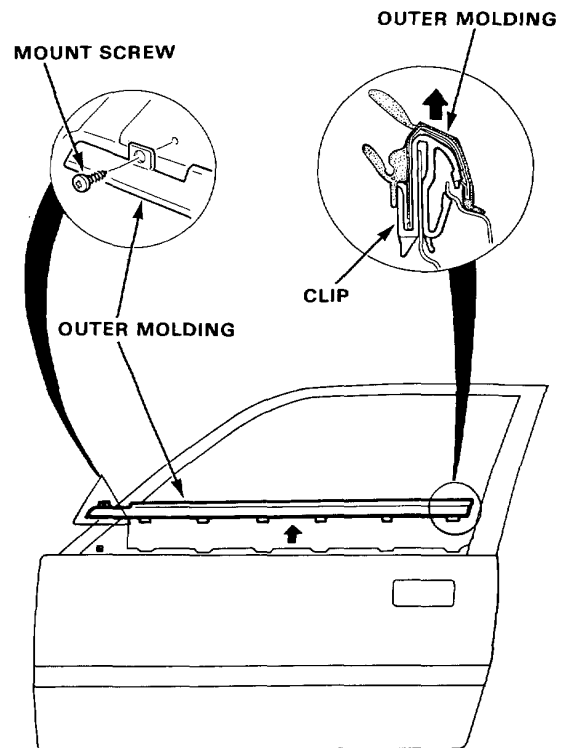



16. Carefully raise the window until you can see its mounting bolts. Loosen the bolts and pull the door glass out through the window slot.

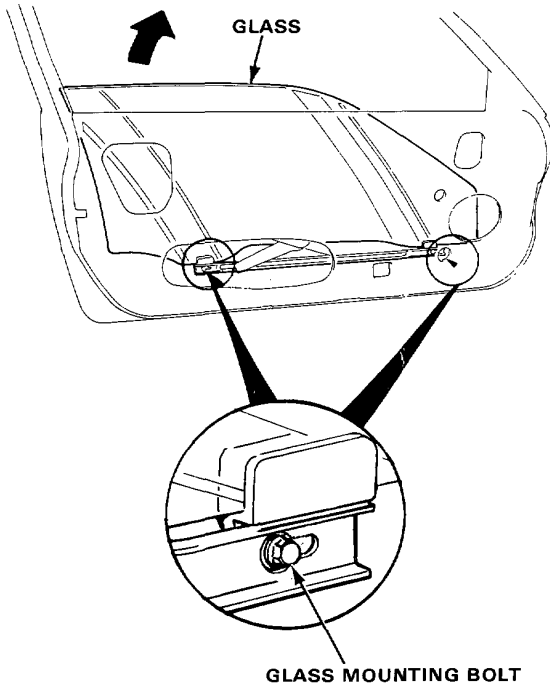

17. Remove the 4 mounting bolts and loosen the 2 motor mounting bolts, then take out the regulator assembly through the lower hole in the door.

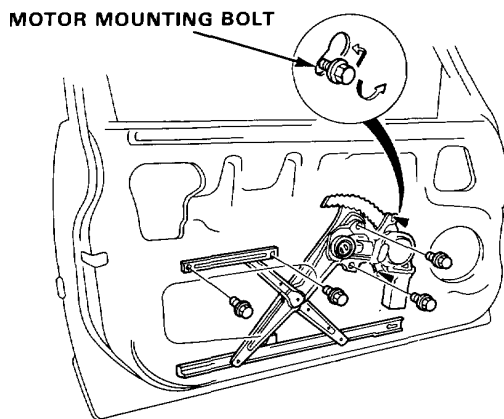

18. Remove the glass run channel.

19. Remove the front channel by removing the 2 bolts and the nut.

NOTE: Before installation, insert the glass run channel into the front channel.

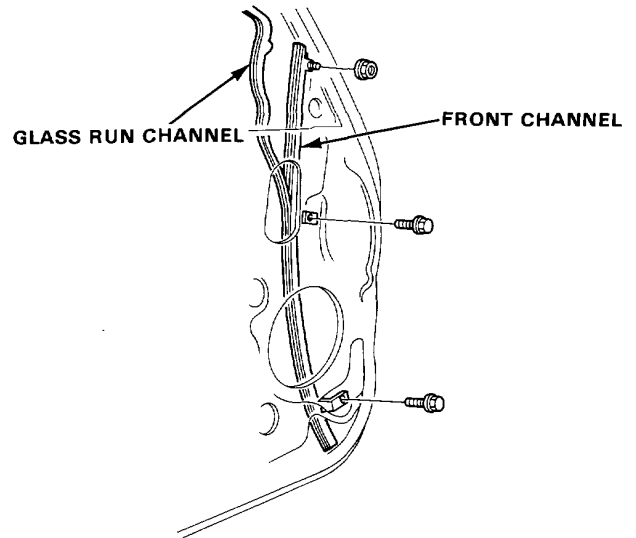

20. Remove the door protector by removing the nut and detach the clips from the inside, or outside.

