

Timing Belt

Replacement

1. Remove the wheel well splash shield.

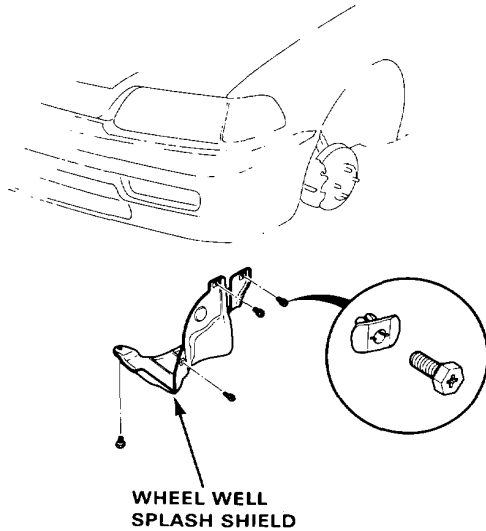

2. Remove the A/C compressor adjust pulley with bracket and the belt (with A/C).

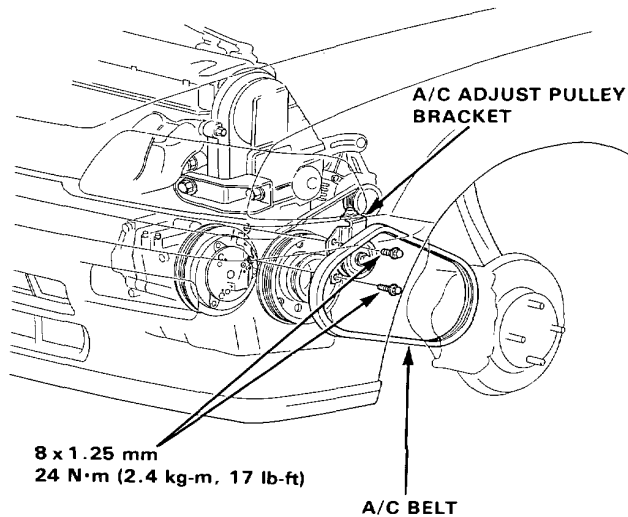

3. Remove the side bracket.
4. Loosen the alternator adjust bolt and through bolt, then remove the belt.

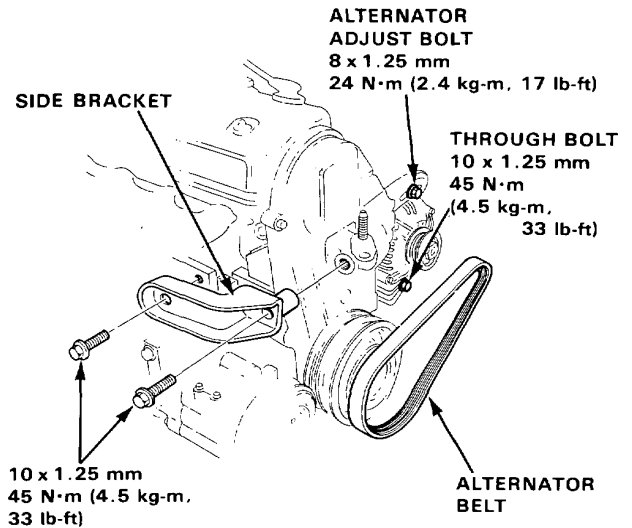

5. After installation, adjust the tension of each belt. See page 5-6 for alternator belt tension adjustment. See page 5-7 for A/C compressor belt tension adjustment.
6. Remove the engine support bolts and nut, then remove the side mount rubber.

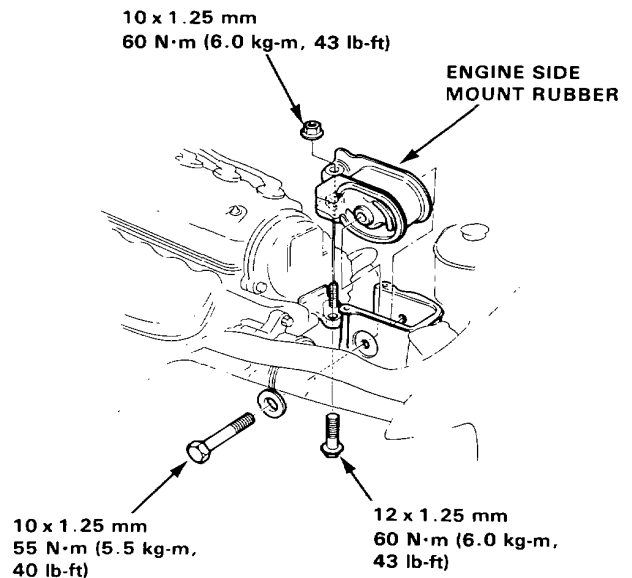



8. Remove the valve cover.
9. Remove the special bolt, then remove crankshaft pulley.
10. Remove the timing belt upper cover and the lower cover.
11. Loosen the adjust bolt, then remove the timing belt.

