

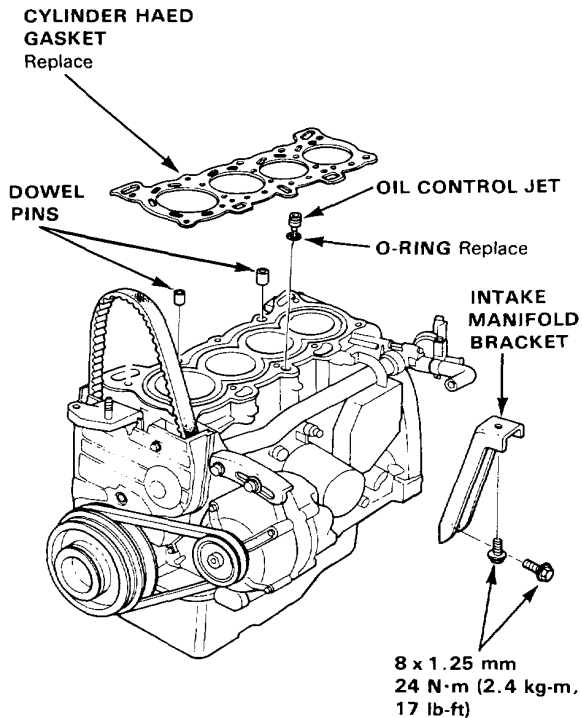

## Installation

1. Install the cylinder head in reverse order of removal:
  - Always use a new head gasket.
  - Cylinder head and engine block surface must be clean.
  - "UP" mark on timing belt pulley should be at the top.
2. Cylinder head dowel pins and oil control jet must be aligned.



3. Install the intake manifold and tighten the nuts in a criss-cross pattern, beginning with the inner nuts.

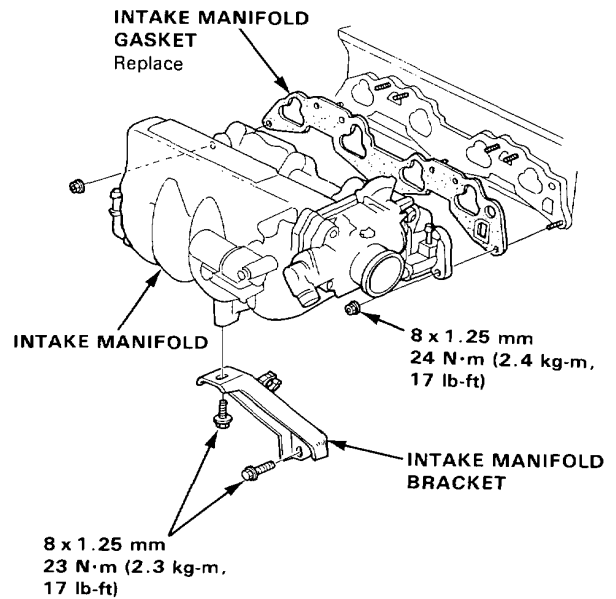

4. Tighten cylinder head bolts in two steps.  
In the first step tighten all bolts and nuts, in sequence, to about 30 N·m (3.0 kg, 22 lb-ft); in the final step tighten, in same sequence, to 68 N·m (6.8 kg-m, 49 lb-ft).

NOTE: Apply engine oil to the cylinder head bolts and the washers.

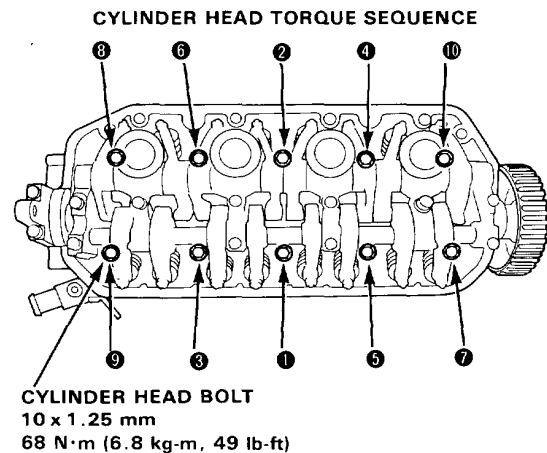

5. Adjust the valve timing.
6. Install the exhaust manifold and bracket.

(cont'd)

# Cylinder Head

## Installation (cont'd)

1.6 l with CATA:

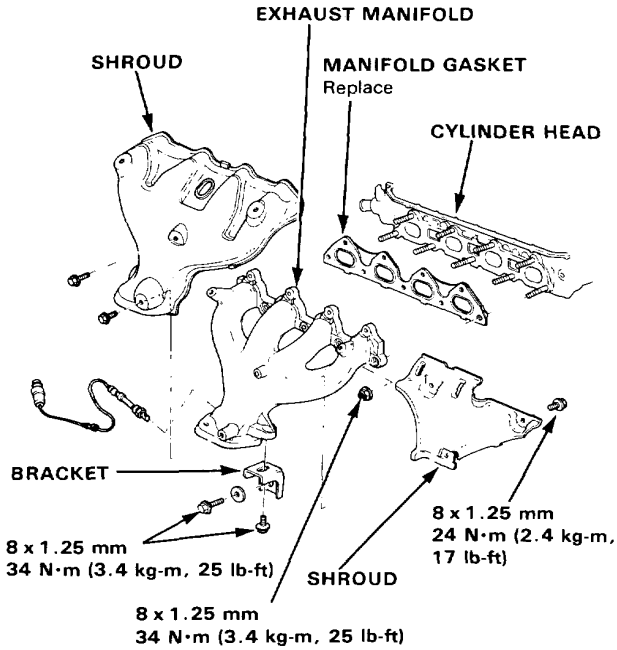

1.6 l without CATA:

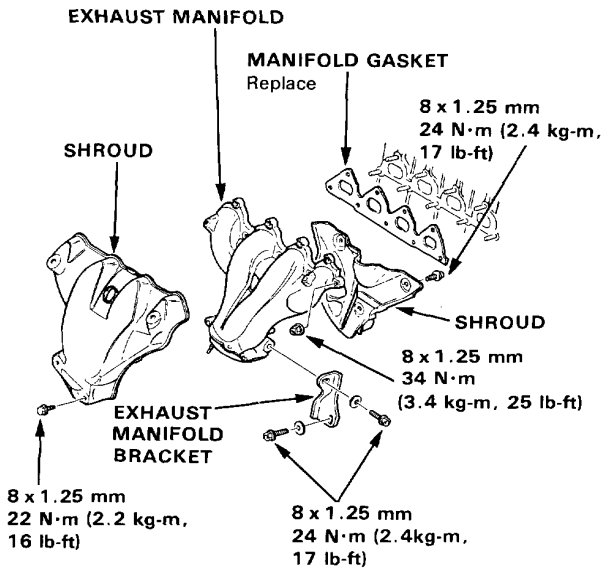

### EXHAUST MANIFOLD TORQUE SEQUENCE

