

# Engine Removal/Installation

## **WARNING**

- Make sure jacks and safety stands are placed properly and hoist brackets are attached to correct positions on the engine. (See Section 1).
- Apply parking brake and block rear wheels, so car will not roll off stands and fall on you while working under it.

**CAUTION:** Use fender covers to avoid damaging painted surfaces.

1. Disconnect the battery negative terminal first then the positive terminal. Remove battery.
2. Unbolt the hood brackets and remove the hood.
  - Disconnect the washer fluid tube.

**CAUTION:** Use care when storing the hood to avoid damaging the paint.

LHD:

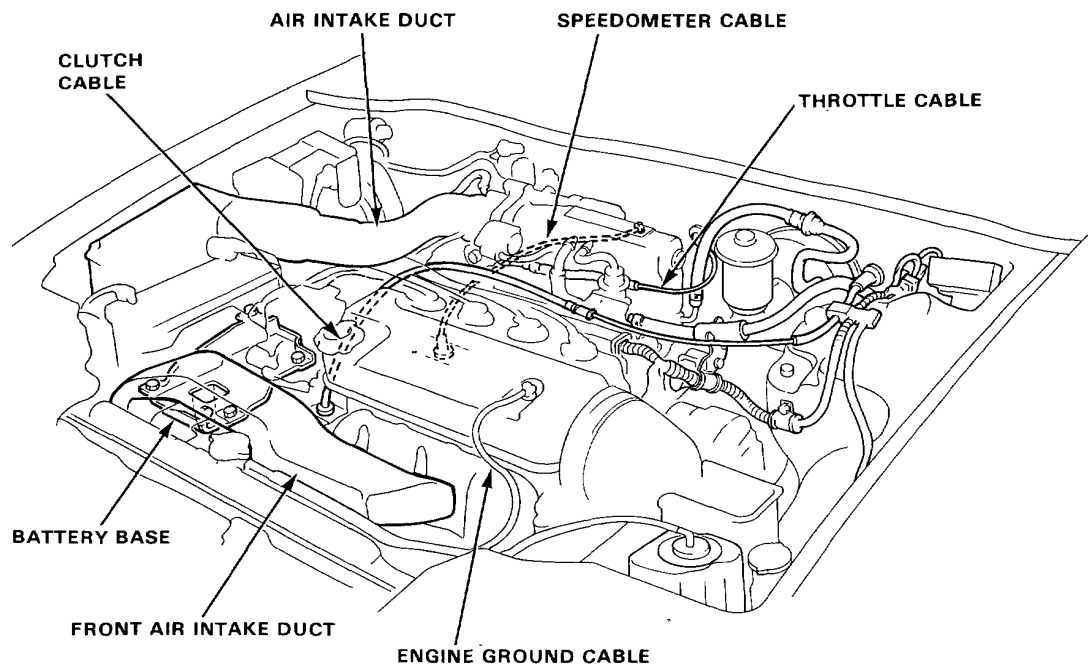

3. Drain the engine oil. Remove the oil filler cap to speed draining. Reinstall the drain plug with a new washer.

4. Drain the coolant from the radiator into a clean pan so it may be re-used. Remove the radiator cap to speed draining.

**WARNING** Use care when removing radiator cap to avoid scalding by hot coolant or steam.

5. Drain transmission oil/fluid. Use a 3/8" drive ratchet wrench to remove the drain plug. Remove the oil filler plug to speed draining. Reinstall the drain plug with a new washer.
6. Remove the air intake duct and front air intake duct.
7. Remove the battery base.

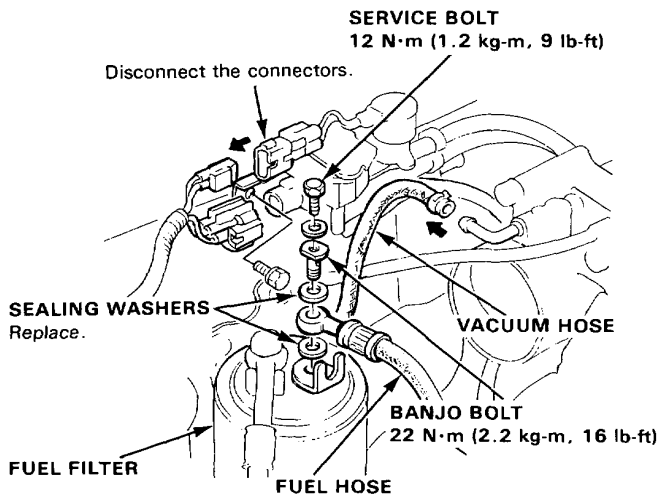

- Relieve fuel pressure by slowly loosening the service bolt on the fuel filler about one turn. (Section 6).

**WARNING** Do not smoke while working on fuel system. Keep open flame away from work area. Drain fuel only into an approved container.

**CAUTION:**

- Before disconnecting any fuel line, the fuel pressure should be relieved as described above.
- Place a shop towel over the fuel filler to prevent pressurized fuel from spraying over the engine.

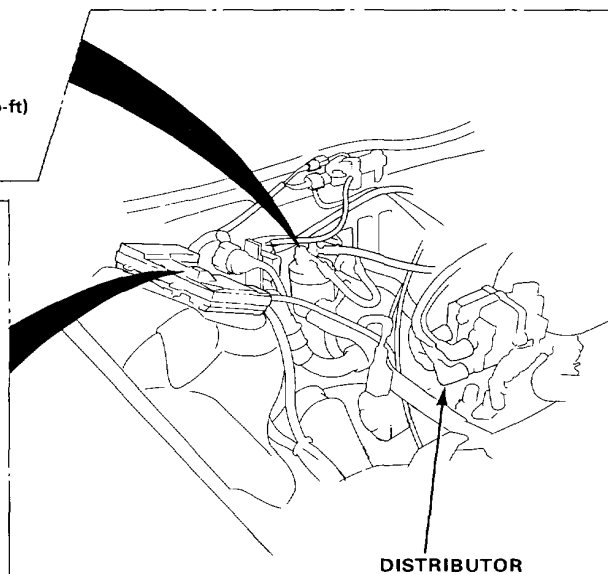
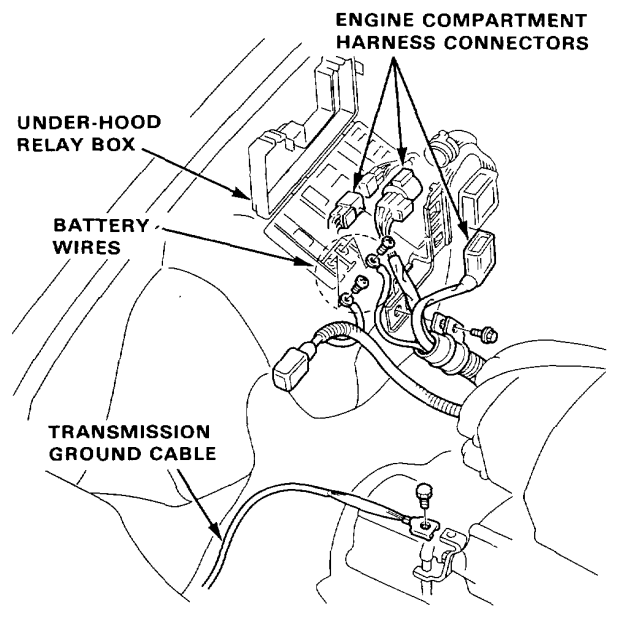

- Disconnect the engine compartment harness connectors, battery wires and transmission ground cable.
- Disconnect the engine wire connectors and spark plug wires.
- Remove the cap and bolts, then remove the distributor from the cylinder head.

**DOHC:**

8 x 1.25 mm  
24 N·m (2.4 kg-m, 17 lb-ft)

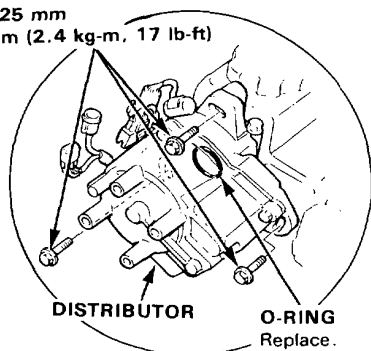

**SOHC:**

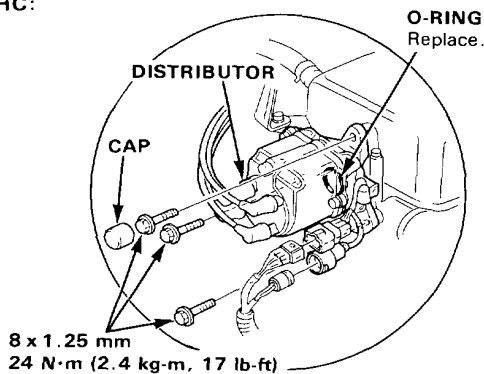

(cont'd)

# Engine Removal/Installation (cont'd)

- Remove the throttle cable by loosening lock the nut and the throttle cable adjust nut, then slip the cable end out of the throttle bracket and accelerator linkage.

**NOTE:** Take care not to bend the cable when removing it. Do not use pliers to remove the cable from the linkage. Always replace a kinked cable with a new one.

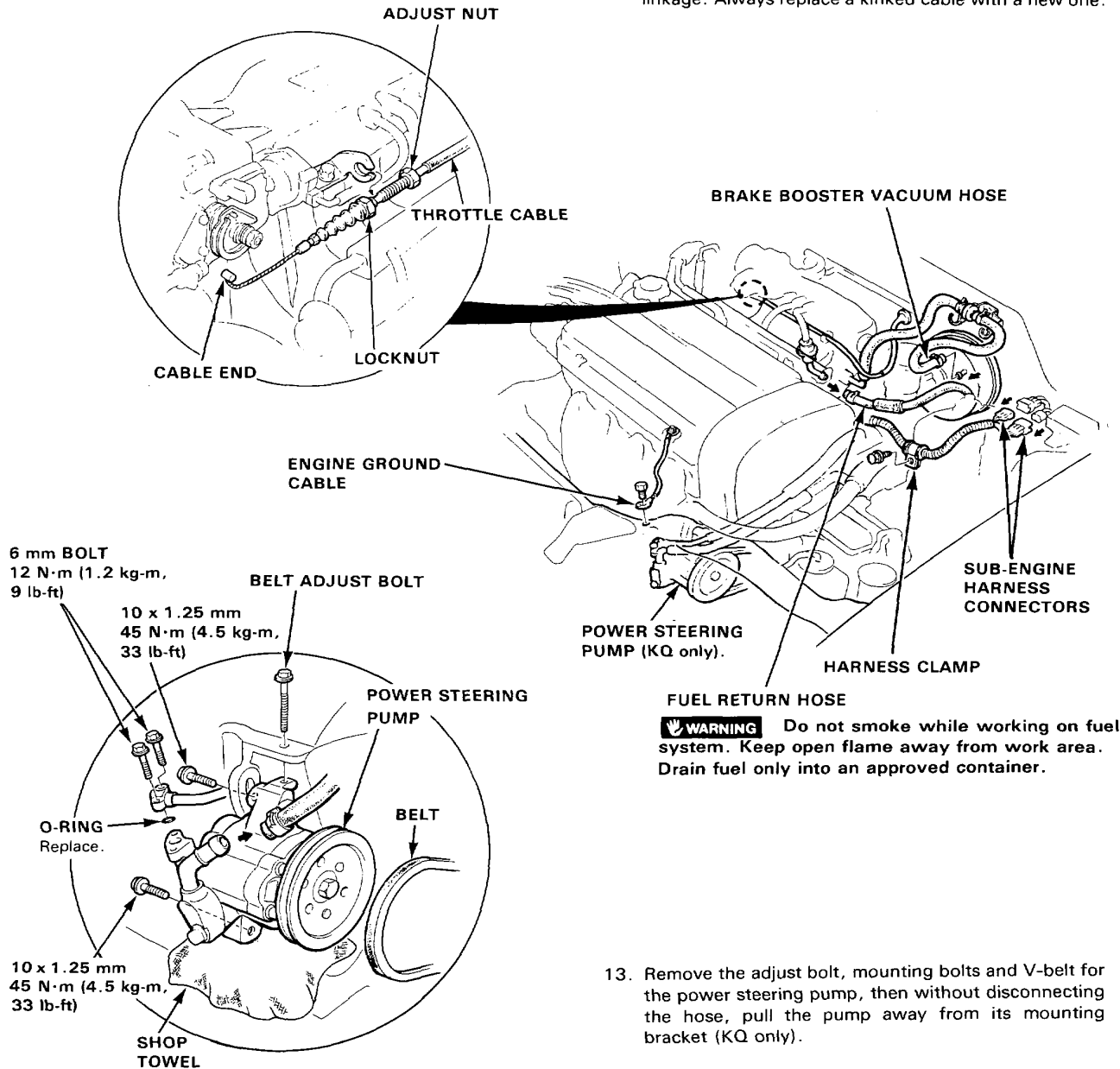

**WARNING** Do not smoke while working on fuel system. Keep open flame away from work area. Drain fuel only into an approved container.

- Remove the adjust bolt, mounting bolts and V-belt for the power steering pump, then without disconnecting the hose, pull the pump away from its mounting bracket (KQ only).



14. Disconnect the radiator hoses and heater hoses.
15. Remove the speedometer cable.

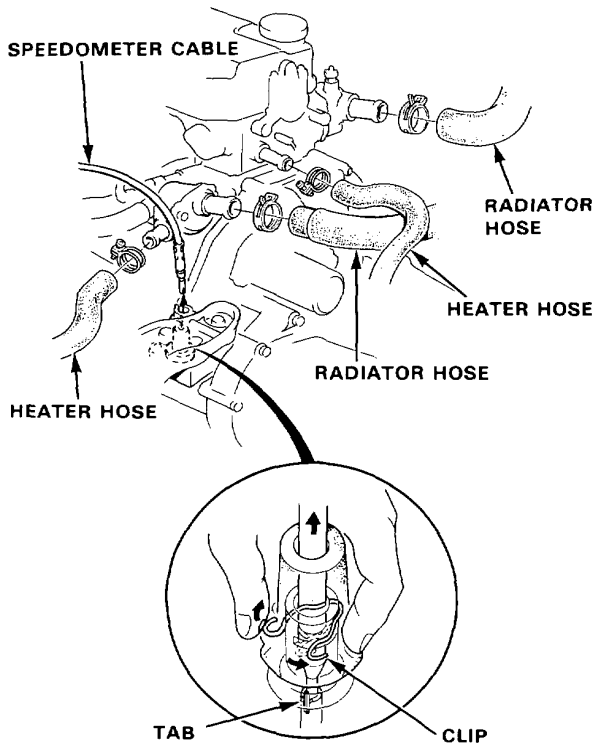

**CAUTION:** Do not remove the holder because the speedometer gear may fall into the transmission housing.

16. Remove the alternator: (LHD only)

- Disconnect the alternator wire harness connectors.
- Remove the adjust bolt and remove the belt.
- Remove the belt alternator mount bolt and remove the alternator.

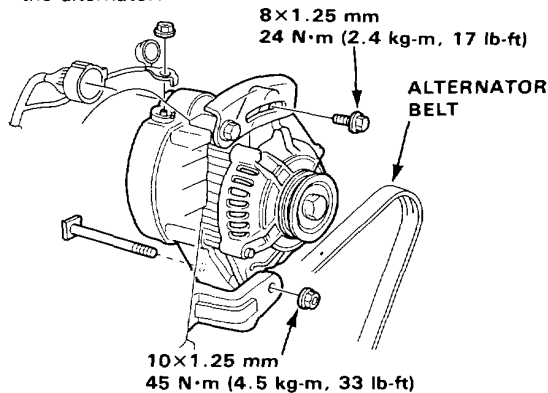

17. On cars with A/C:

- Loosen the belt adjust bolt and idle pulley nut.
- Remove the compressor mount bolts, then lift the compressor out of the bracket with hoses attached, and wire it up to the front beam.

**NOTE:** The compressor can be moved without discharging the air conditioner system.

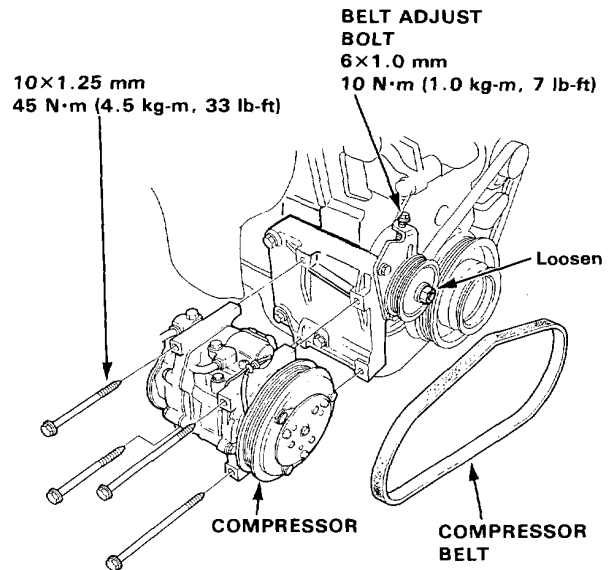

If necessary:

- Disconnect the suction and discharge hoses from the compressor.

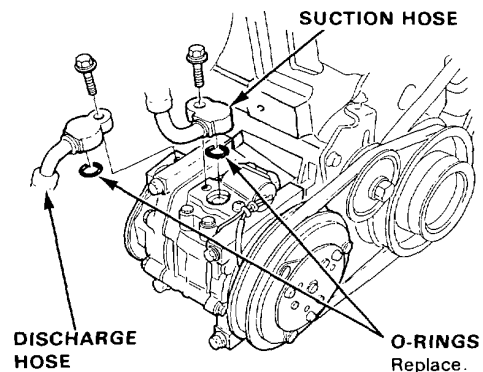

(cont'd)

# Engine Removal/Installation (cont'd)

18. Remove the shift lever torque rod, shift rod and clutch cable.

NOTE: On reassembly, slide the retainer back into place after driving in the spring pin.

19. Remove the right and left driveshafts. (See Section 10)

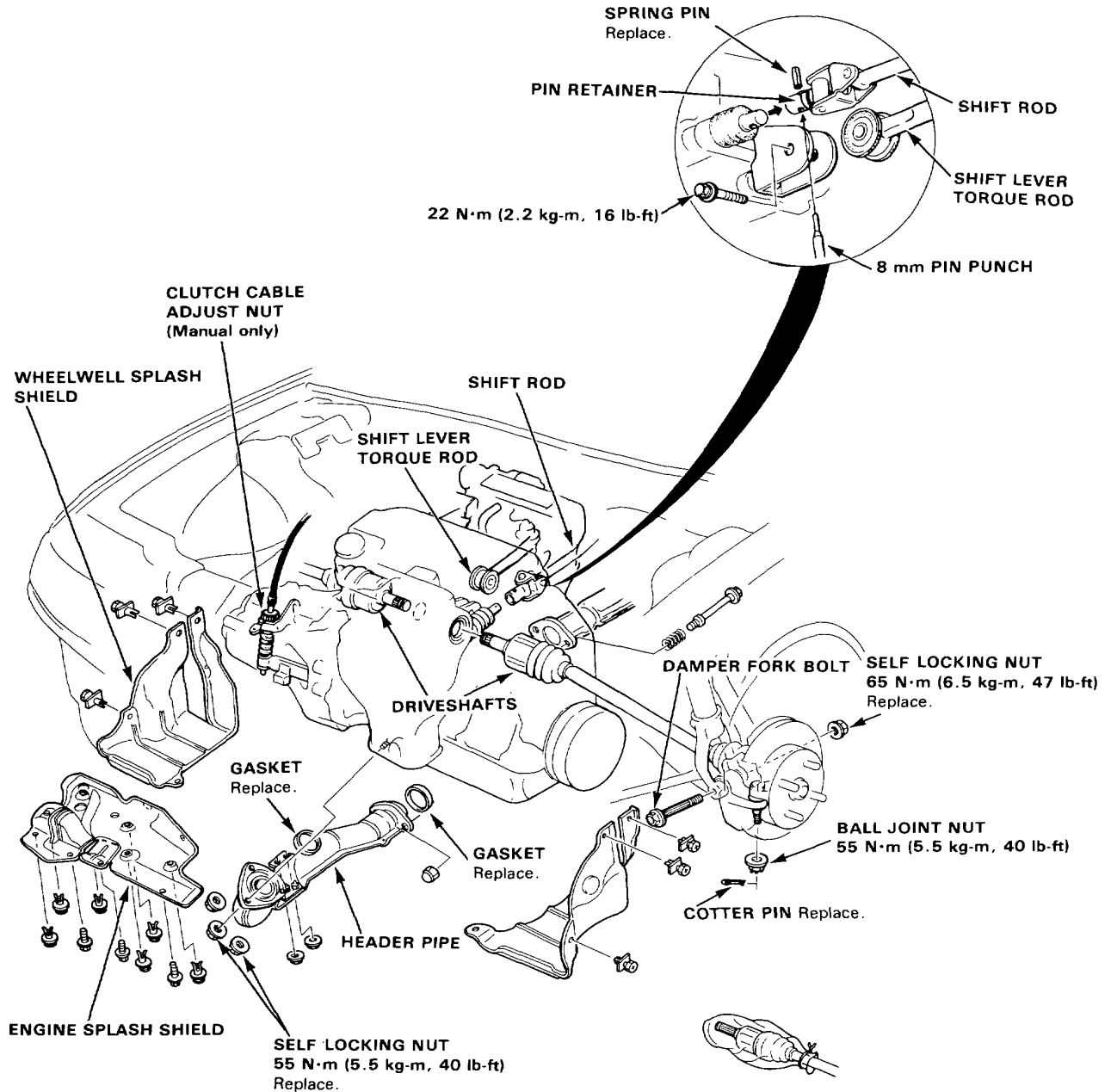

NOTE: Coat all precision finished surfaces with clean engine oil or grease.  
Tie Plastic bags over the drivehaft ends.



- Attach a chain hoist to the engine block hoist brackets and raise the hoist just enough to remove slack from the chain.

**NOTE:**

To attach rear engine chain, remove the plastic radiator hose bracket and hook chain to top of clutch cable bracket.

- Remove the rear transmission mount bracket.
- Remove the bolts from the front transmission mount.
- Remove the bolts from the engine side mount.
- First remove the mount nut from under the transmission housing and remove the bolt from the side transmission mount.

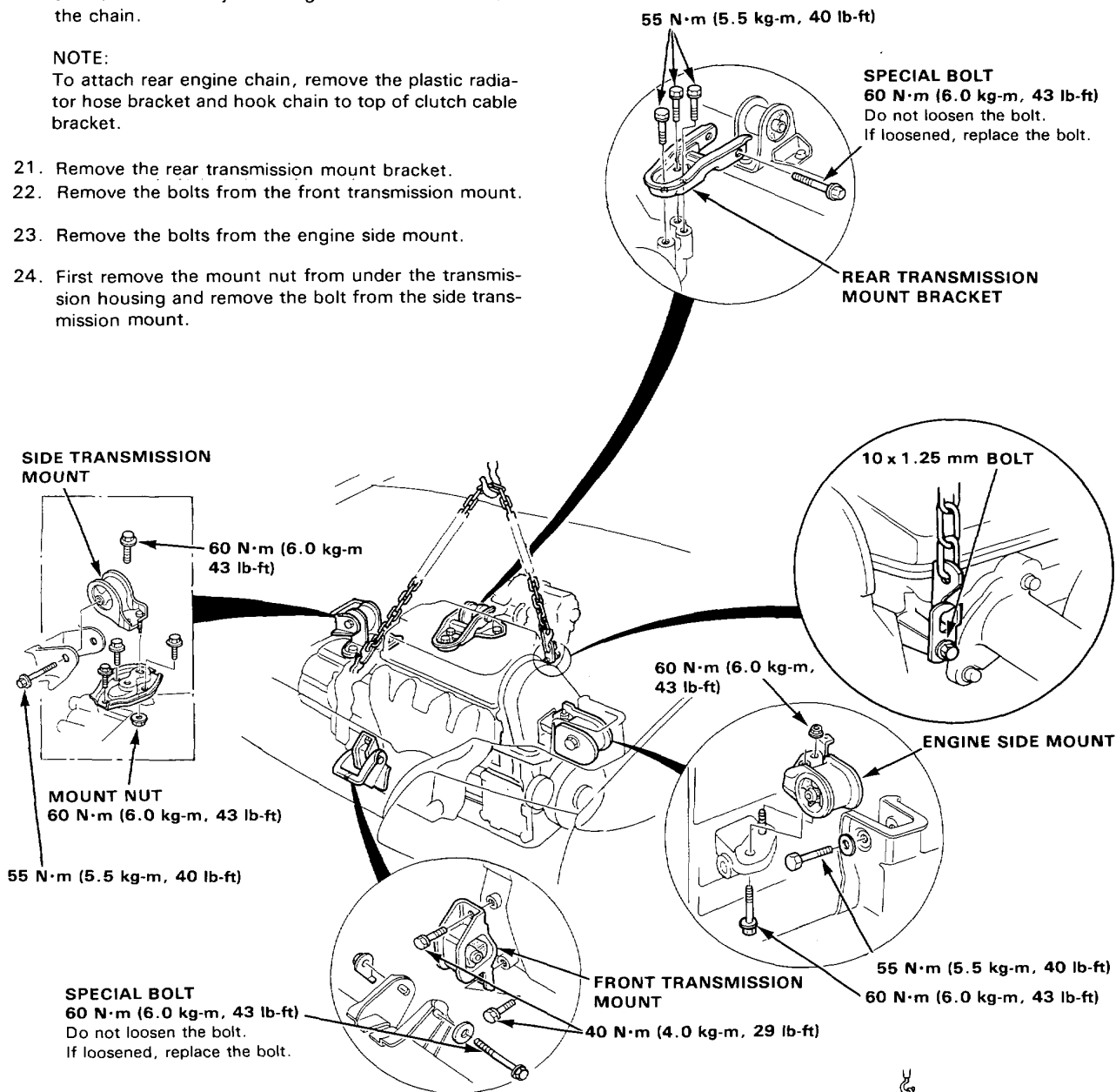

- Check that the engine/transaxle is completely free of vacuum, fuel, and coolant hoses, and electrical wires.
- Slowly raise the engine approximately 6" and stop. Check once again that all wires and hoses have been disconnected from the engine/transaxle.
- Raise the engine/transaxle all the way and remove it from the car.

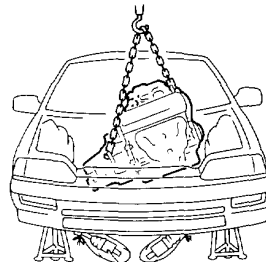

(cont'd)

# Engine Removal/Installation (cont'd)

28. Install the engine in the reverse order of removal.  
After the engine is in place:

- Torque engine mount bolts in sequence shown.

**CAUTION:** Failure to tighten the bolts in the proper sequence can cause excessive noise and vibration, and reduce bushing life: check that the bushings are not twisted or offset.

- Check that the spring clip on the end of each driveshaft clicks into place.

**CAUTION:** Use new spring clips on installation.

- Inspection for fuel leakage.

After assembling fuel line parts, turn on the ignition switch (do not operate the starter) so that the fuel pump is operated for approximately two seconds and the fuel is pressurized. Repeat this operation two or three times and check whether any fuel leakage has occurred at any point in the fuel line.

- Bleed air from the cooling system at the bleed bolt with the heater valve open.
- Adjust the throttle cable tension. (See Section 11).
- Adjust the alternator belt tension.
- Check the clutch pedal free play.
- Check that the transmission shifts into gear smoothly.
- Reinstall the A/C compressor and A/C wiring.
- Clean battery posts and cable terminals with sandpaper, assemble, then apply grease to prevent corrosion.
- Check the ignition timing. (See Section 16).
- Charge the system and test performance. (See Section 15).

## ENGINE MOUNT TORQUE SEQUENCE

NOTE: Check the mount and bracket for damage.

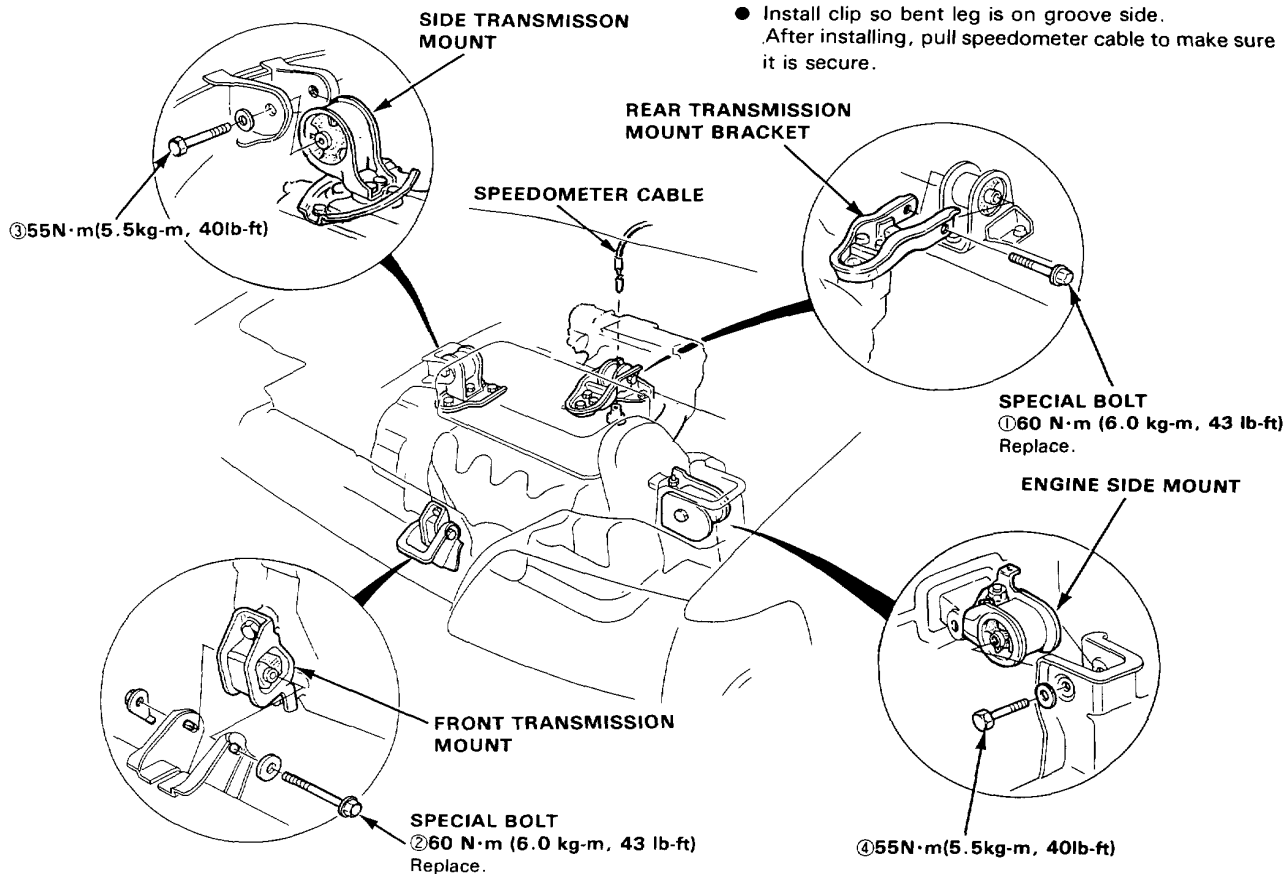

## Speedometer cable Installation:

- Align tab on cable end with slot in holder (page 5-45).
- Install clip so bent leg is on groove side. After installing, pull speedometer cable to make sure it is secure.



**Additional Torque Specifications:**

