

Water Pump

Replacement

1. Remove the timing belt (SOHC: page 5-18, DOHC: page 5-24).
2. Remove the water pump by removing five bolts.

WATER PUMP

Inspect for signs of seal leakage or bearing deterioration.

NOTE: Small amount of "weeping" from bleed hole is normal.

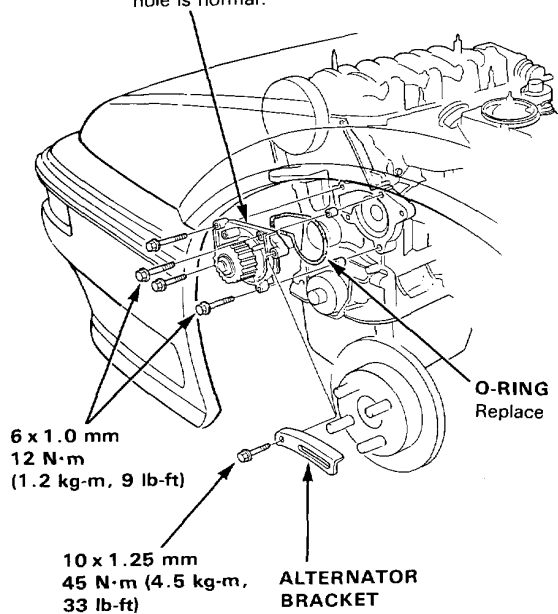

3. Install the water pump in the reverse order of removal.