

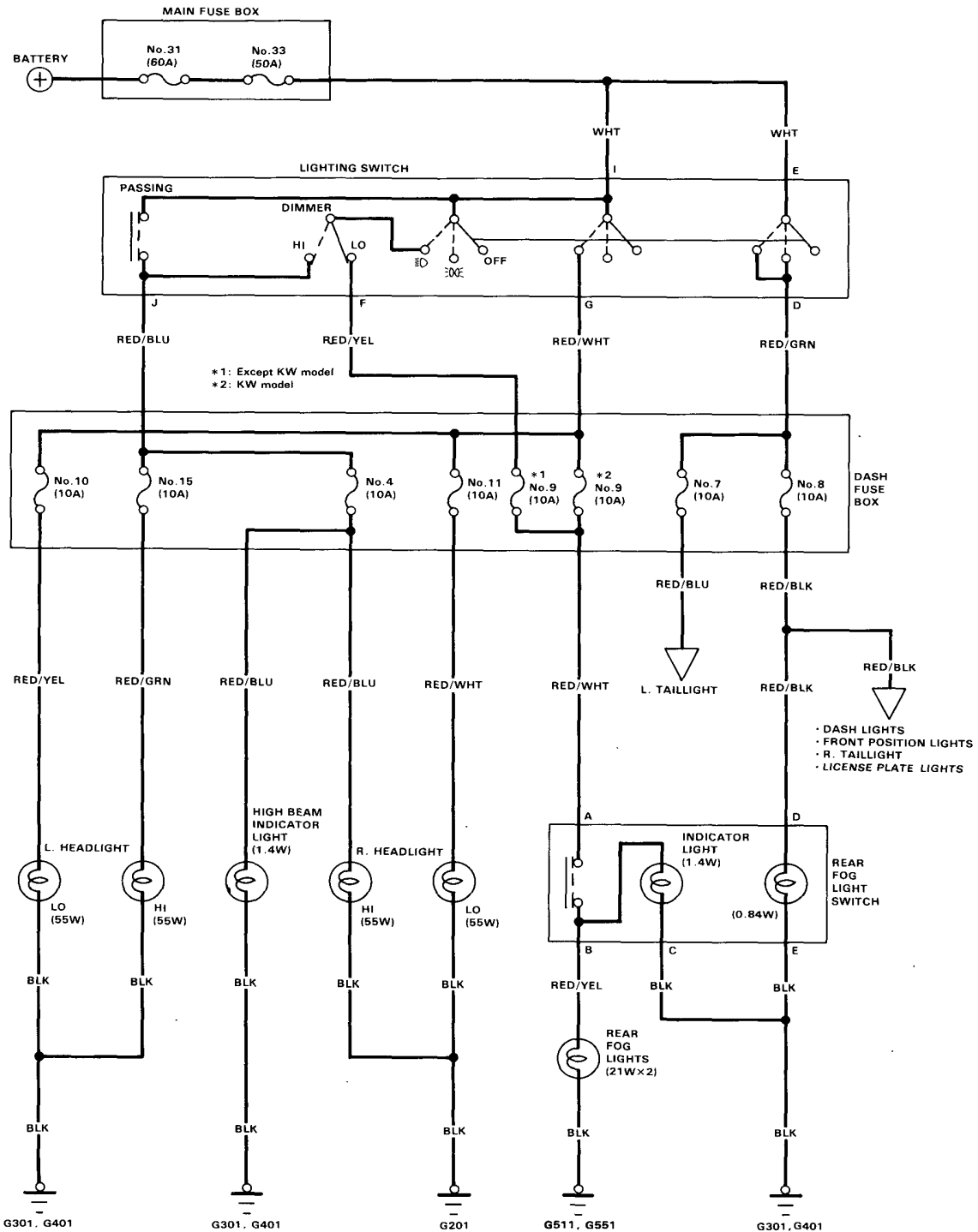

Circuit Diagram (KG, KF, KB, KW and KX models)



Lighting System

Circuit Diagram (With Daytime Light)

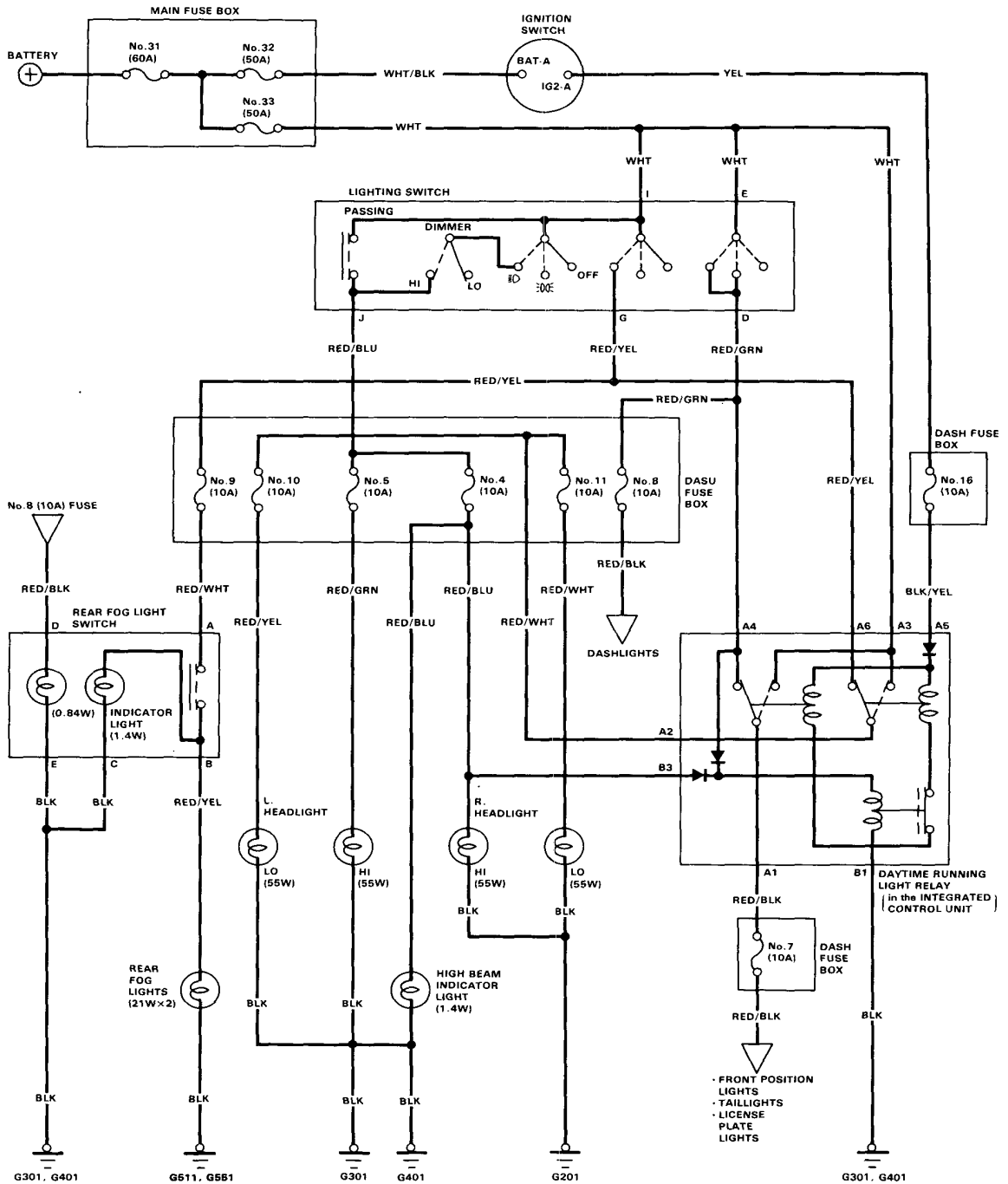

Lighting System

Circuit Diagram (KQ and KY models)

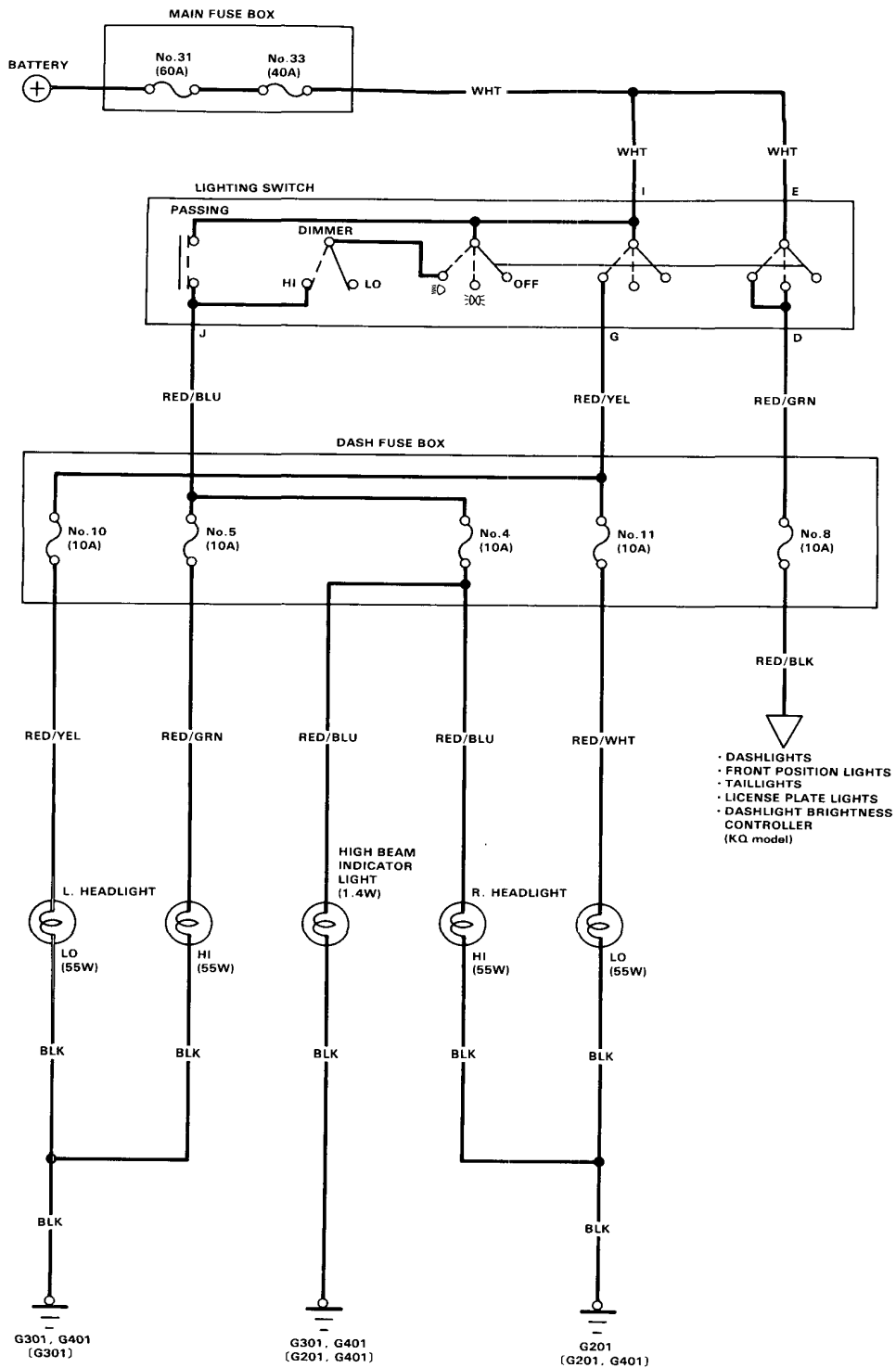

[]: RHD