

Compressor

Clutch Overhaul

1. Remove the center bolt.

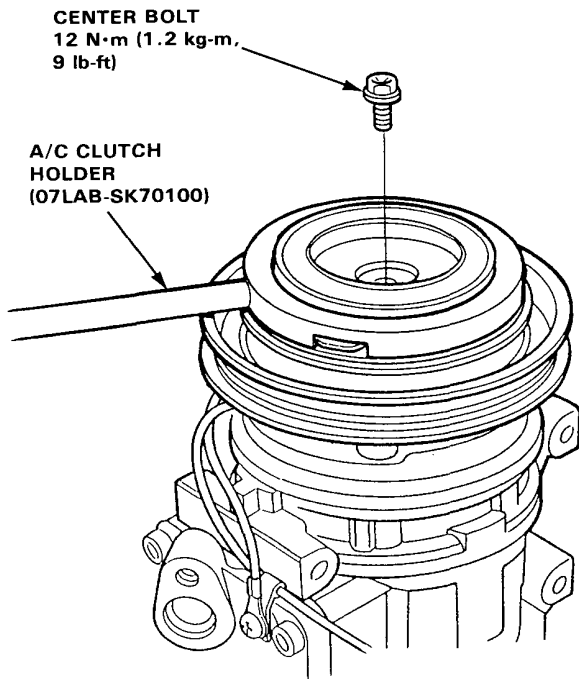

2. Remove the pressure plate and shim(s) taking care not to lose the shims.

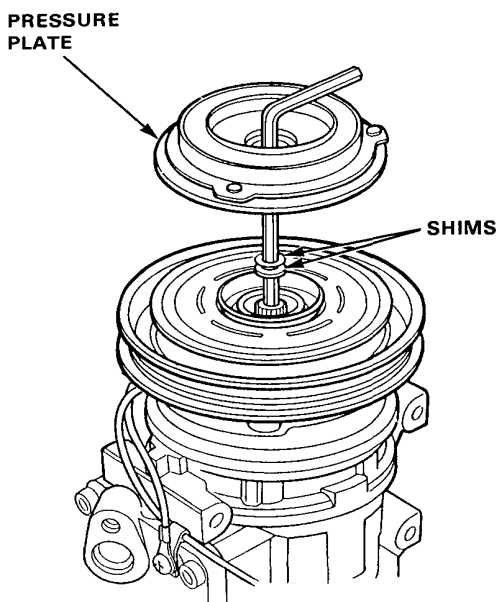

3. Use circlip pliers to remove the snap ring B, then remove the pulley.

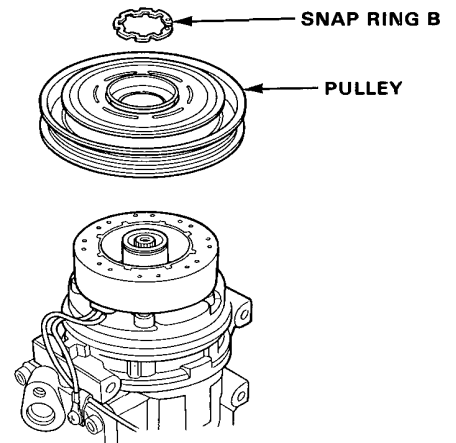

4. Remove the snap ring A and the field coil.

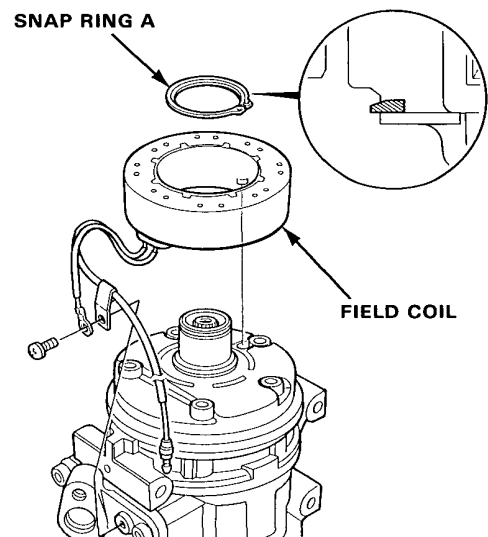

5. Install in the reverse order of removal and:
 - Install the field coil with the wire side facing up (see above).
 - Clean the pulley and compressor sliding surfaces with non-petroleum solvent.
 - Check the pulley bearings for excessive play.
 - Make sure the circlip is fitted to the groove properly.
 - Apply locking agent to the thread of the center bolt and tighten it securely.
 - Make sure that the pulley turns smoothly.