



Replacement

1. If the compressor is marginally operable, run the engine at idle speed and turn on the air conditioner fan a few minutes, then shut the engine off and disconnect the battery negative terminal.
2. Discharge the refrigerant very slowly from the system.
3. Disconnect the suction and discharge hoses from the compressor.

CAUTION:

Cap the open fittings immediately to keep moisture and dirt out of the system.

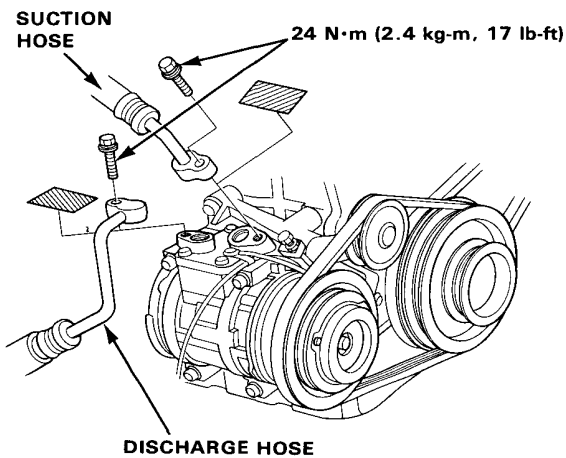

4. Disconnect the compressor connector and the clamp.

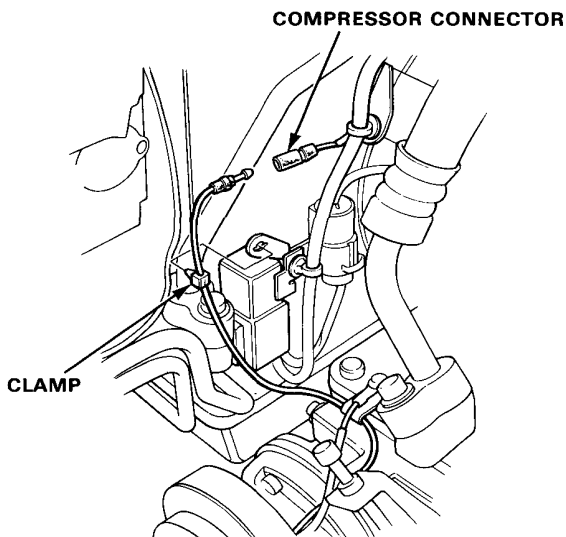

5. Loosen the idle pulley stay bolt. Loosen the lock nut and adjusting bolt, then remove the compressor belt.

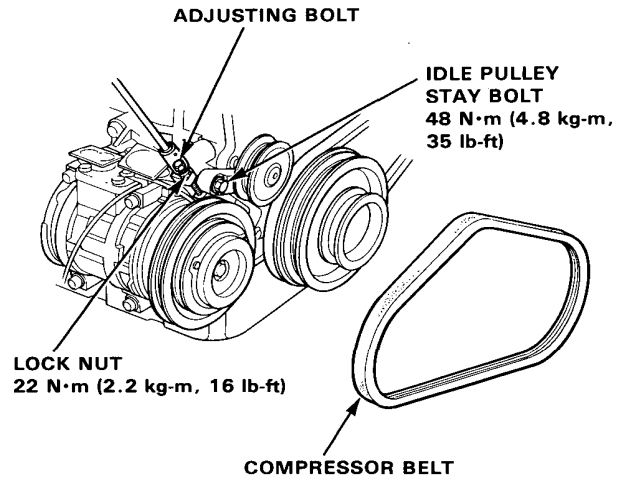

6. Remove the compressor mounting bolts (4) and compressor. Rest the compressor on the front beam.

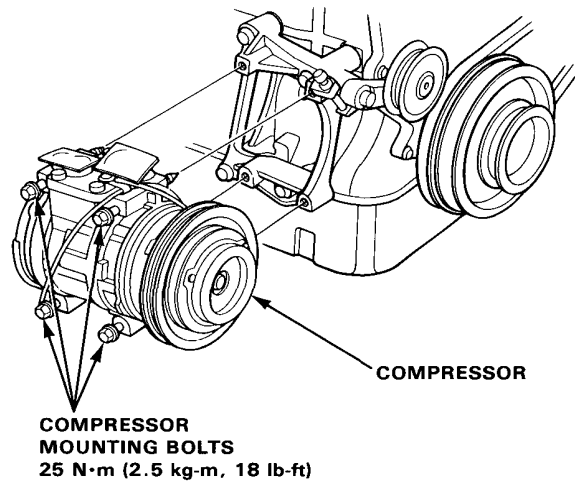

(cont'd)

Compressor

Replacement (cont'd)

7. Remove the mounting bolts (4) and compressor bracket with idle pulley.

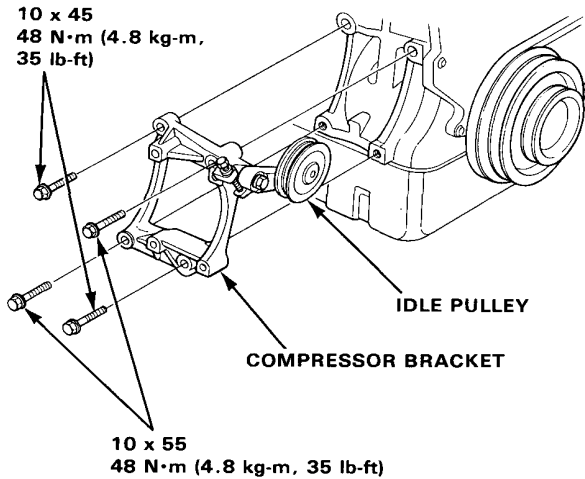

8. Remove the compressor.

9. Install in the reverse order of removal and:
- If a new compressor is installed, calculate the amount of refrigerant to be drained through the suction fitting on the compressor: 80 cc (2 2/3 fl oz,) minus contents of old compressor, equals amount to drain from new compressor.
 - Adjust the compressor belt.

- ① Measure the deflection when 98 N (10 kg, 22 lb) force is applied between the pulleys.

Belt tension	
New belt	Used belt
4.5—6.5 mm (0.18—0.26 in)	7.0—9.0 mm (0.28—0.35 in)

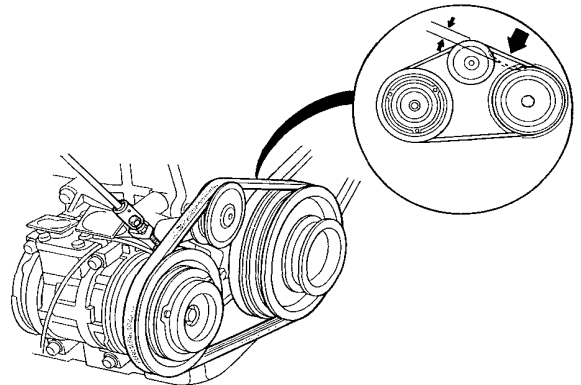

- ② When using ND tension gauge;

Belt tension	
New belt	Used belt
539—735 N (55—75 kg, 121—165 lb)	343—490 N (35—50 kg, 77—110 lb)

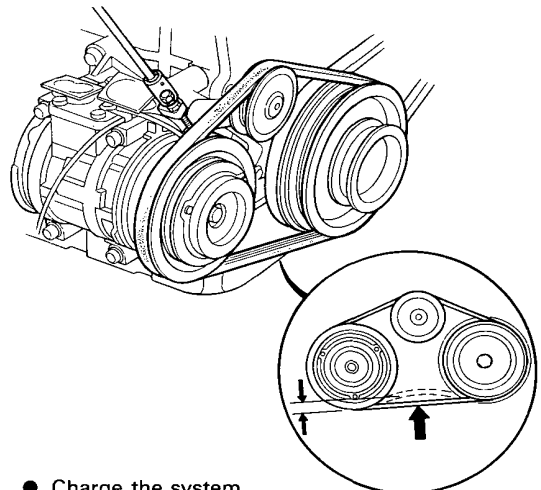

- Charge the system.
- Test the performance.