

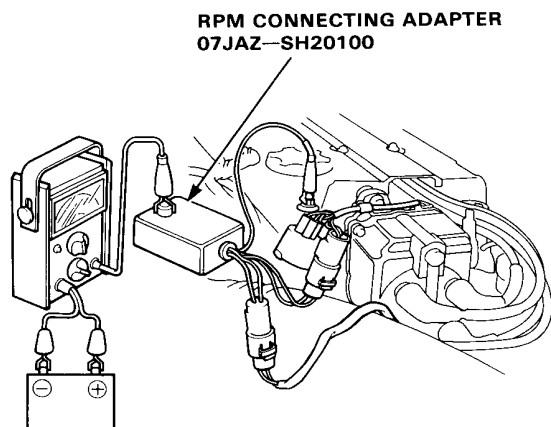

Idle Speed Inspection/Adjustment

1. Start the engine and warm it up to normal operating temperature (the cooling fan comes on).
2. Connect a tachometer.



3. Disconnect the 2P connector from the EACV.

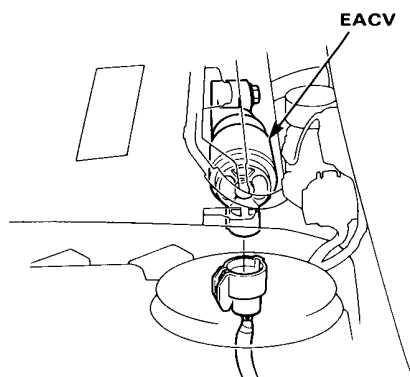

4. Check idling in no-load conditions in which the headlights, blower fan, rear defogger, cooling fan, and air conditioner are not operating.

Idle speed should be: $650 \pm 50 \text{ min}^{-1} \text{ (rpm)}$

Adjust the idle speed, if necessary, by turning the idle adjusting screw.

NOTE: If the idle speed is excessively high, check the throttle control system (page 6-78).

IDLE ADJUSTING SCREW

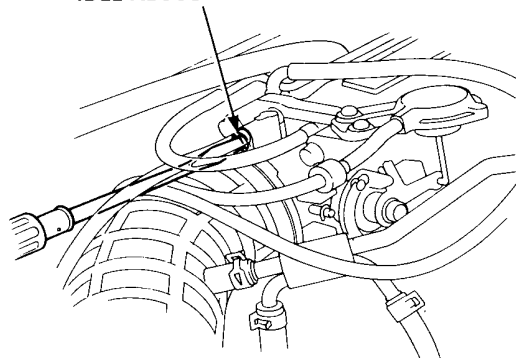

5. Turn the ignition switch OFF.
6. Reconnect the 2P connector on the EACV, then remove HAZARD fuse in the main fuse box for 10 seconds to reset ECU.
7. Restart and idle the engine with no-load conditions in which the headlights, blower fan, rear defogger, cooling fan, and air conditioner are not operating for one minute, then check the idle speed.

Idle speed should be: $750 \pm 50 \text{ min}^{-1} \text{ (rpm)}$

8. Idle the engine for one minute with headlights (Hi) and rear defogger ON and check the idle speed.
9. Idle the engine for one minute with heater fan switch at HI and air conditioner on, then check the idle speed.

Idle speed should be: $810 \pm 50 \text{ min}^{-1} \text{ (rpm)}$

NOTE: If the idle speed is not within specifications, see System Troubleshooting Guide on page 6-45.