

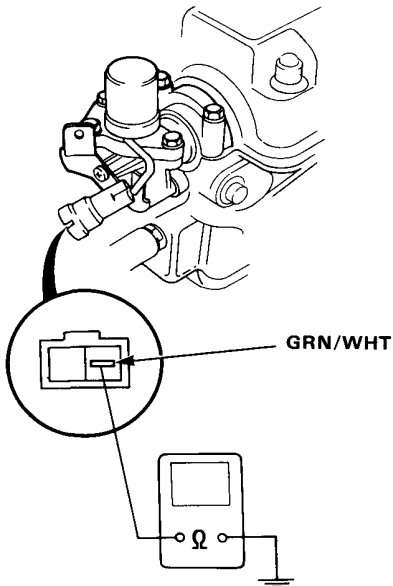

Spool Valve Inspection

1. Disconnect the 2P connector from the spool solenoid valve.
2. Measure resistance between the GRN/WHT terminal and body ground.
Resistance: approx 14-30 ohms



3. If the resistance is within specifications, remove the spool valve assembly from the cylinder head, and check the spool valve filter for clogging.
 - If there is clogging, replace the engine oil filter and the engine oil.

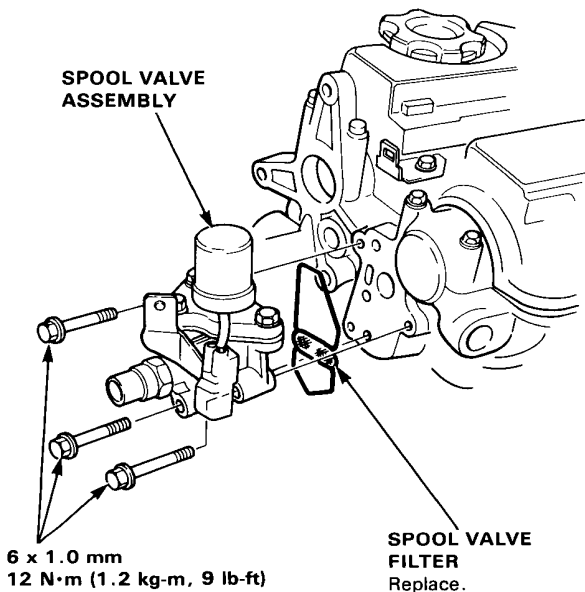

4. If filters are normal, push the spool valve with the finger and check its movement.
 - If spool valve is normal, check the engine oil pressure.

