



Replacement

NOTE:

- Set the No.1 piston at TDC (page 5-45) before remove the timing belt.
- Inspect the water pump (page 5-77) after remove the timing belt.

1. Remove the wheel well splash shield.

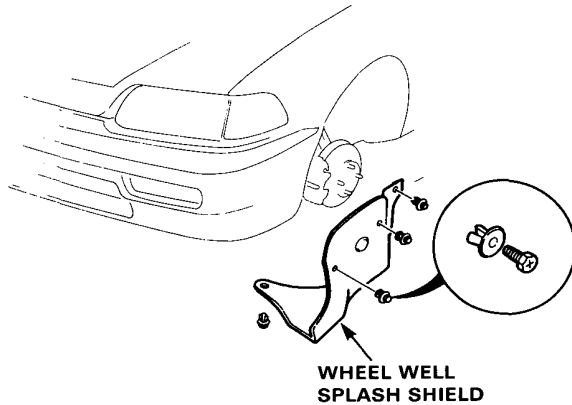

2. Loosen the air conditioner (A/C) adjusting bolt and idel pulley bolt, then remove the A/C belt.

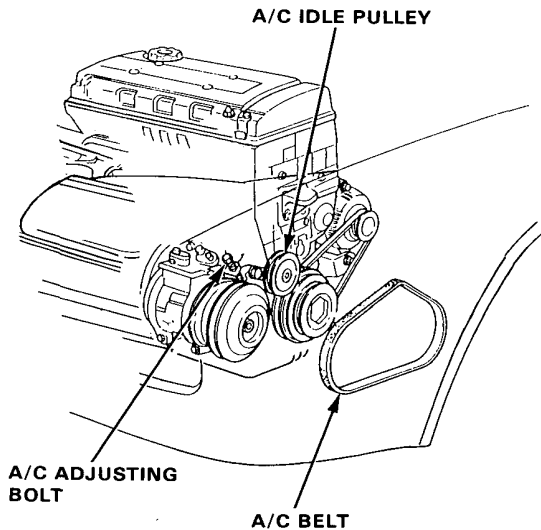

3. Loosen the alternator adjusting bolt and through bolt, then remove the belt.

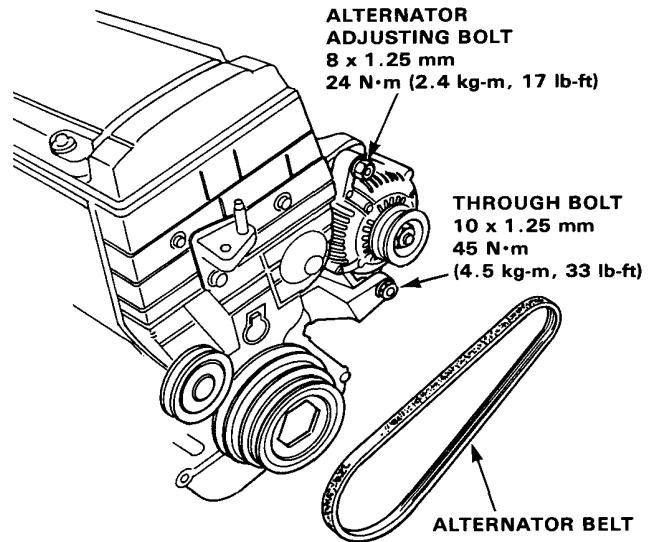

4. After installation, adjust the tension of each belt.
 - See base manual for alternator belt tension adjustment.
 - See page 5-20 for A/C compressor belt tension adjustment.
5. Remove the engine support bolts and nut, then remove the side mount rubber.

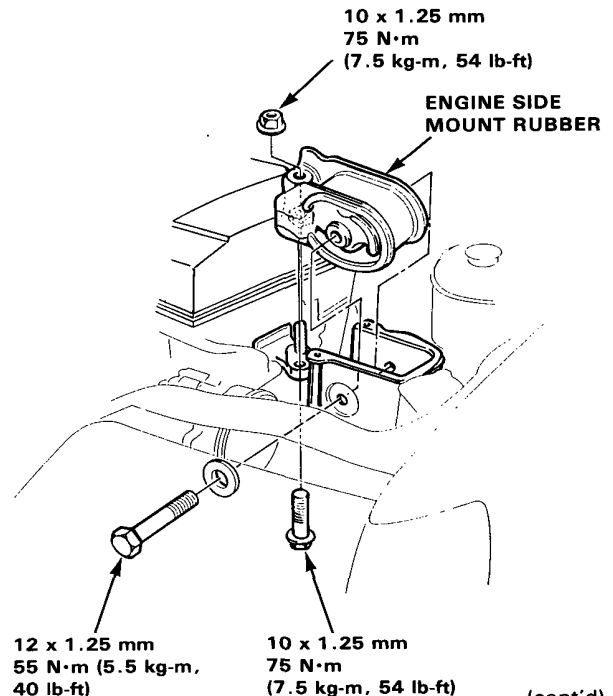

(cont'd)

Timing Belt

Replacement (cont'd)

6. Remove the ignition wire cover and ignition wire (page 5-17).
7. Remove the valve cover.
8. Remove the timing belt middle cover.
9. Remove the crankshaft pulley with the special tools.
10. Remove the timing belt lower cover.
11. Loosen the adjusting bolt, then remove the timing belt.
12. Install in the reverse order of removal; adjust the valve timing (page 5-45).
13. Carry out timing belt tension adjustment (page 5-42).

