

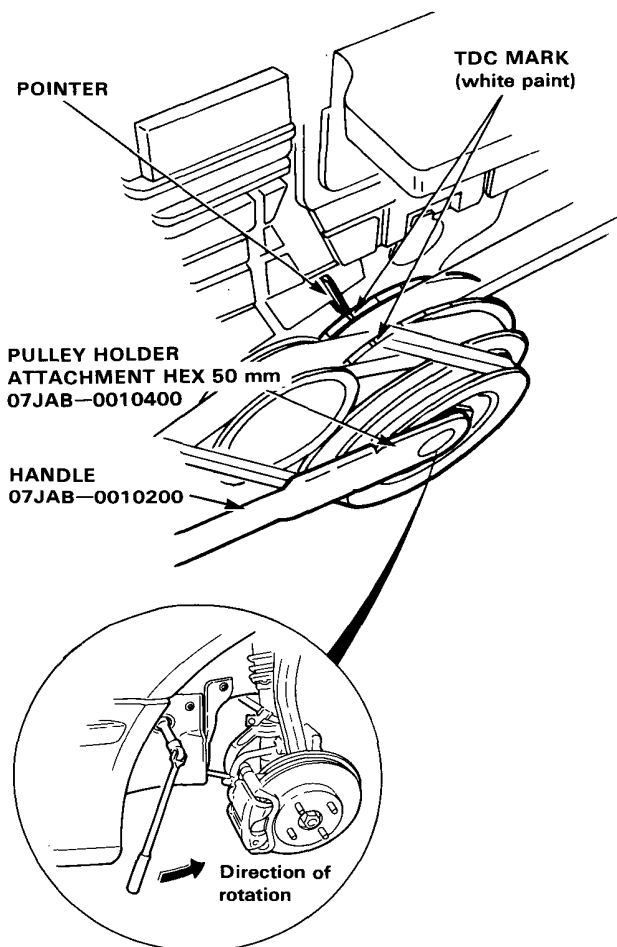

## Positioning Crankshaft Before Installing Timing Belt

1. Remove the ignition wire cover and ignition wire (page 5-17).
2. Remove the valve cover (page 5-41).
3. Rotate the crankshaft with special tools, then set the No.1 piston at TDC.



NOTE: If the pulley bolt loosens while turning the crank, retorque it to 120 N·m (12.0 kg-m, 87 lb-ft).

4. Make sure that the camshaft pulleys are at the compression top dead center of the No.1 piston.

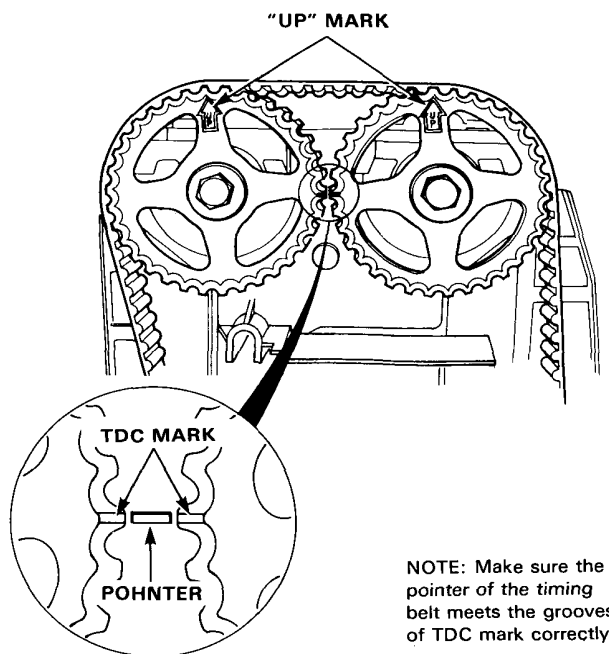

5. If the camshaft pulleys are not positioned at the compression top dead center of the No.1 piston, remove the timing belt and adjust the position in following procedure, then reinstall the timing belt.
  - Refer to page 5-43 for removal and reinstallation of the timing belt.
  - Bring the "UP" marks of the camshaft pulleys to the top, and adjust the pointer of the timing belt back cover to the groove of the TDC mark on the pulleys.
  - Adjust the holes on the camshaft holder to the camshaft holes, insert pin driver of 5.0 diameter and fix them as the top dead center.
  - Remove the pin-drivers after the belt has been reinstalled.

