

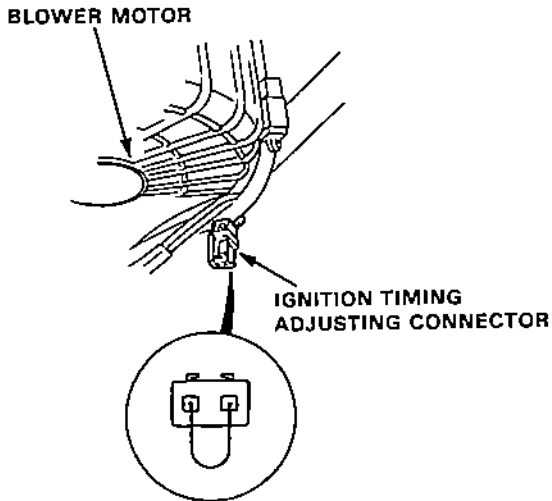

## Ignition Timing Inspection and Setting

1. Start the engine and allow it to warm up (cooling fan comes on).
2. Connect the BRN and GRN/WHT terminals of the ignition timing adjusting connector (BLU) with a jumper wire.  
NOTE: L.H. drive type shown, R.H. drive type is symmetrical to L.H. drive type.



3. Remove the ignition wire cover. Then connect a timing light to the No. 1 ignition wire; while the engine idles, point the light toward the pointer on the timing belt cover.  
NOTE: Do not damage the cover when removing the nuts.

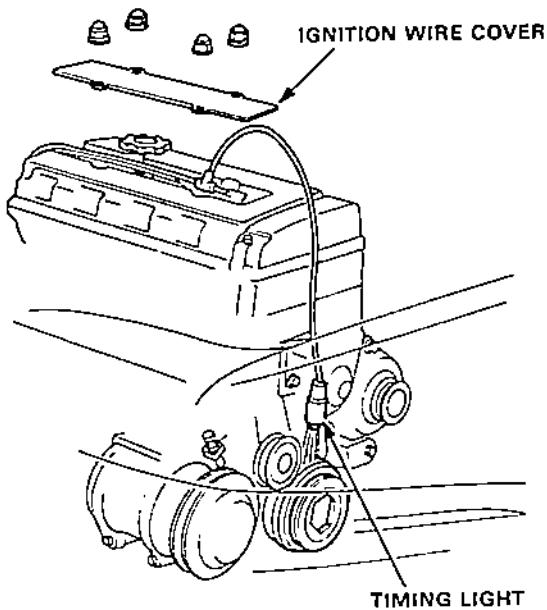

4. Adjust ignition timing, if necessary, to the following specifications:  
Ignition Timing:  
 $15^\circ \pm 2^\circ$  BTDC (RED) at  $750 \pm 50$  min<sup>-1</sup> (rpm) in neutral

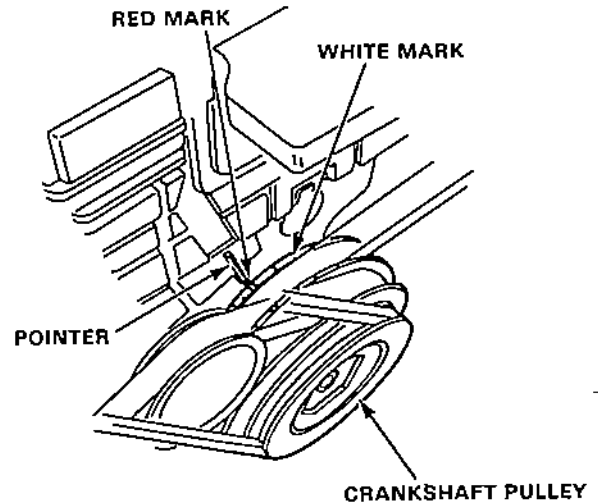

5. Adjust as necessary by loosening the distributor adjusting bolts, and turn the distributor housing counter clockwise to advance the timing, or clockwise to retard the timing.

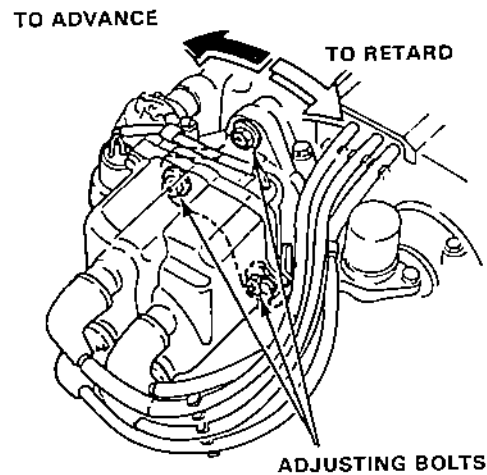

6. Tighten the adjusting bolts recheck the timing.
7. Remove the jumper wire from the ignition timing adjusting connector (BLU).