

Cylinder Head

Installation

Install the cylinder head in reverse order of removal:
NOTE:

- Always use a new head gasket.
- Cylinder head and engine block surface must be clean.
- "UP" mark on timing belt pulley should be at the top.
- Turn the crankshaft so that No. 1 is at TDC (page 5-45).

1. Cylinder head dowel pins and head oil control orifice must be aligned.

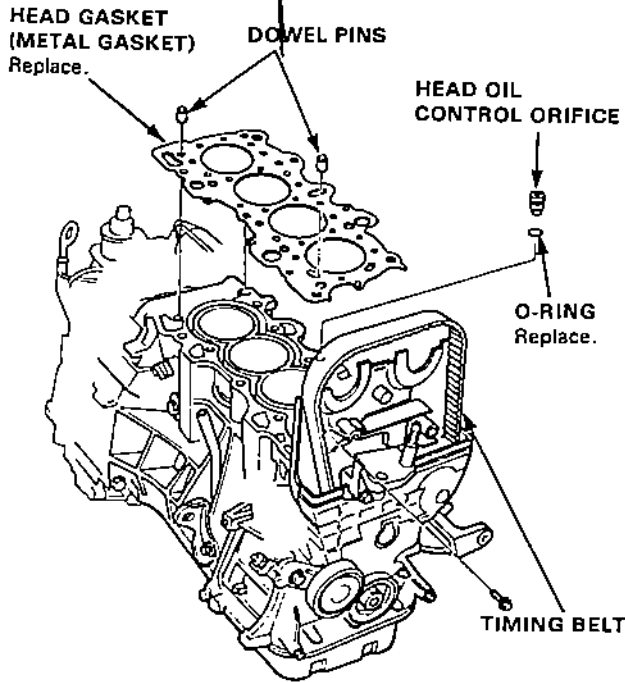

2. Tighten cylinder head bolts in two steps. In the first step tighten all bolts, in sequence, to about 30 N·m (3.0 kg-m, 22 lb-ft); in the final step tighten, in same sequence, to 85 N·m (8.5 kg-m, 61 lb-ft)
NOTE: Apply engine oil to the cylinder head bolts and the washers.

CYLINDER HEAD BOLTS TORQUE SEQUENCE

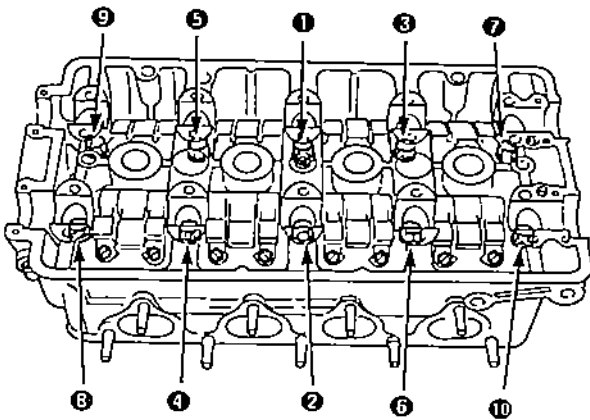

3. Install the intake manifold and tighten the nuts in a criss-cross pattern in two or three steps, beginning with the inner nuts.

INTAKE MANIFOLD

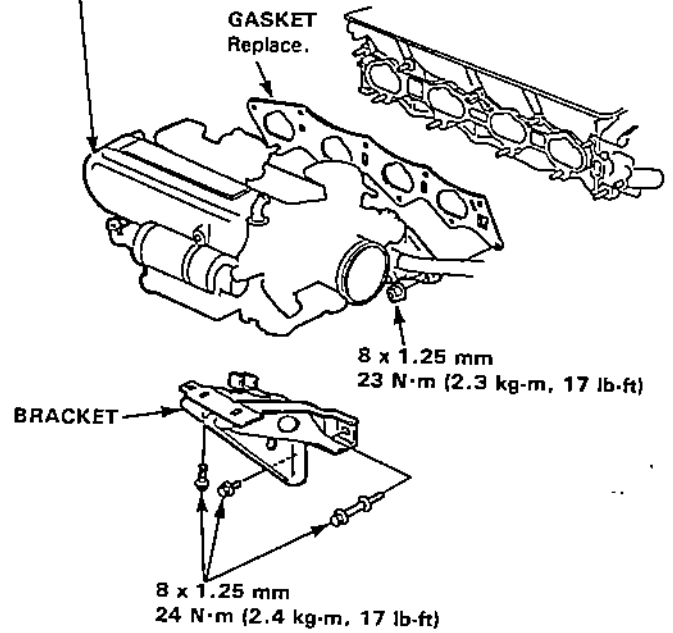

4. Install the exhaust manifold and tighten the new self-locking nuts in a criss-cross pattern in two or three steps, beginning with a inner nuts.

CAUTION:

- Install the oxygen sensors after connecting the exhaust manifold and the exhaust pipe A.
- Do not use air wrench for tightening self-locking nuts of exhaust pipe A, if the oxygen sensors are not to be removed.

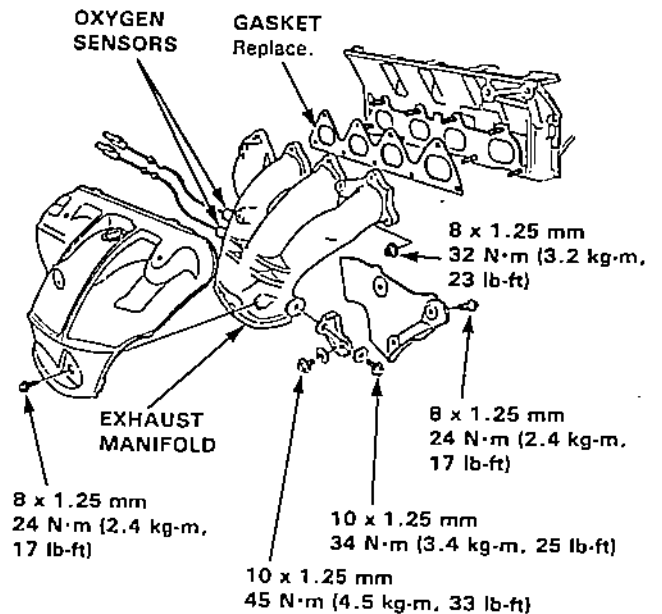



5. Install the camshafts and the camshaft seals with the open side (spring) facing in.

CAUTION:

- Make sure that the keyways on the camshafts are facing up. (NO.1 cylinder TDC).
- Valve locknuts should be loosened and adjust screws backed off before installation.
- Replace the rocker arms in these original positions.
- Set the O-ring and dowel pin to the center of No.3 camshaft holder.
- Seal housing surface should be dry.
- Apply a light coat of oil to camshaft and inner lip of seal.

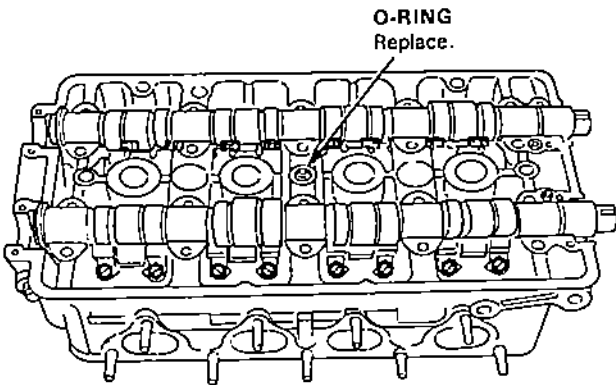

6. Apply liquid gasket to the head mating surfaces of the No.1 and No.5 camshaft holders, then install them, along with the No.2, 3 and 4.
- Apply liquid gasket to the shaded areas.

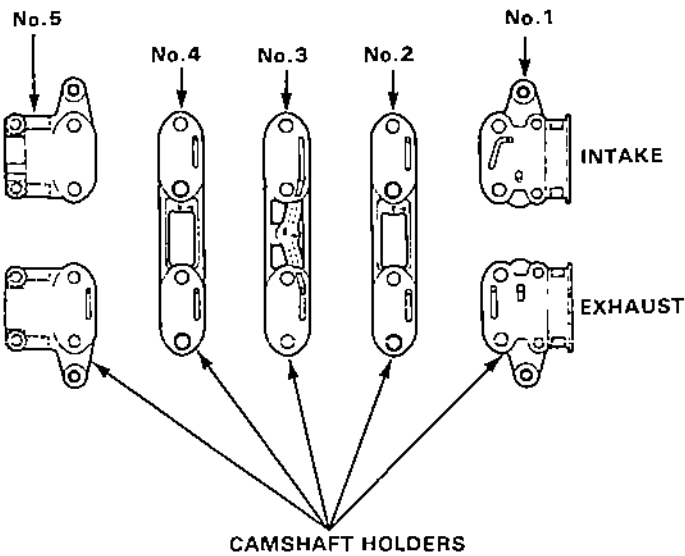

7. Set the camshaft folders and camshaft holder pipes, then tighten temporarily the bolts.

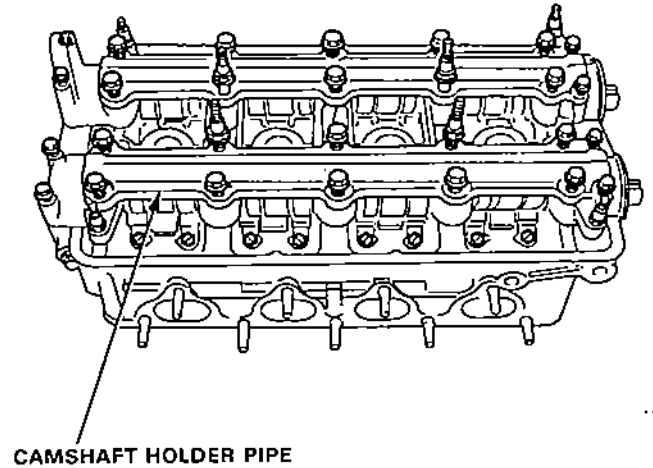

8. Press the camshaft seals securely.

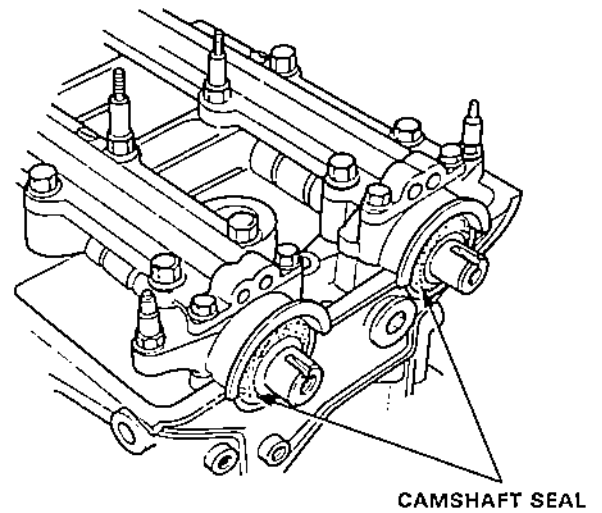

(cont'd)

Cylinder Head

Installation (cont'd)

- Tighten each bolt two turns at a time in the sequence shown below to insure that the rockers do not bind on the valves.

CAMSHAFT HOLDER BOLT TORQUE SEQUENCE

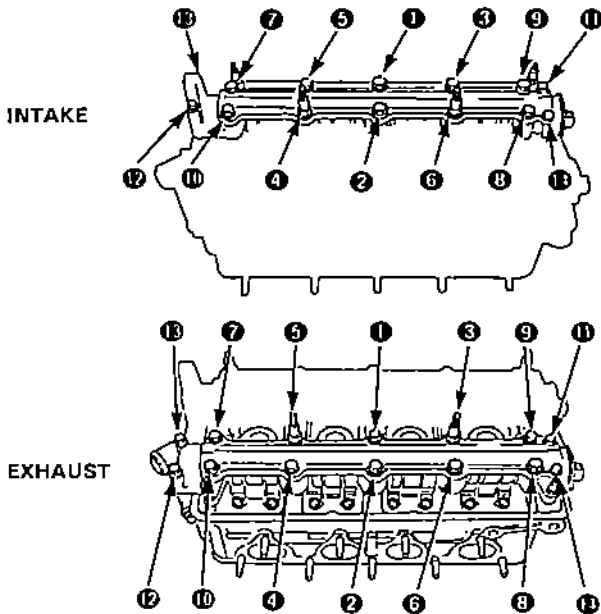

- ①~⑥: 8 x 1.25 mm
22 N·m (2.2 kg-m, 16 lb-ft)
- ⑦~⑫: 6 x 1.0 mm
11 N·m (1.1 kg-m, 8 lb-ft)

- Install keys into grooves in camshafts.
- Push camshaft pulleys onto camshafts, then tighten retaining bolts to torque shown.

NOTE: To set the No.1 piston at TDC, align the hole on the camshaft with the hole in the No.1 camshaft holders and drive 5.0 mm pin drivers into the holes.

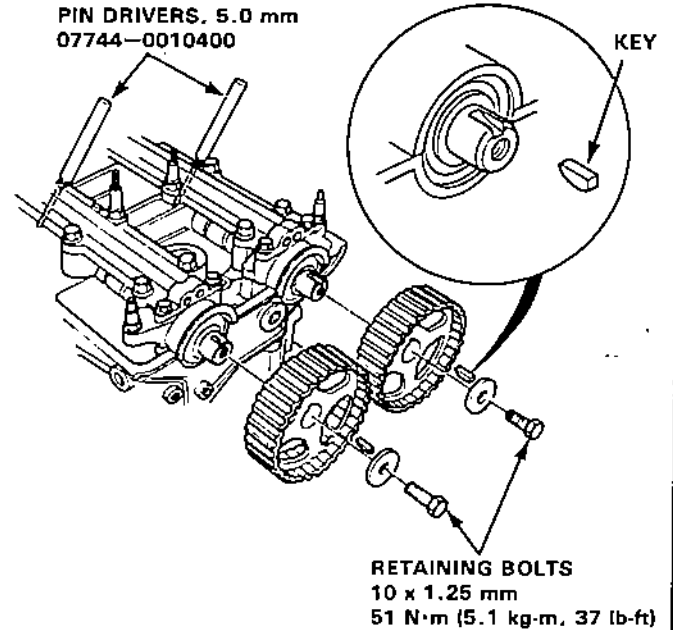

- Adjust the valve timing (page 5-45).
- Adjust the valve clearance (page 5-21).
- Inspect the rocker arms using special tools (page 5-57).
- After installation, check that all hoses and connectors are installed correctly.

NOTE: Refer to Shop Manual "B16A ENGINE Maintenance and Repair (code No. 62PR300)" for overhaul of cylinder head.