

# PGM-FI Control System

## Troubleshooting Flowchart — TDC/CRANK/CYL Sensors



Self-diagnosis LED indicator blinks four times: A problem in the circuit of the CRANK Sensor.



Self-diagnosis LED indicator blinks eight times: A problem in the circuit of the TDC Sensor.



Self-diagnosis LED indicator blinks nine times: A problem in the circuit of the CYL Sensor.



- Check Engine warning light has been reported on.  
- LED indicates CODE 4.

Turn the ignition switch OFF.

Remove HAZARD fuse in the main fuse box for 10 seconds to reset ECU.

Start engine.

Is Check Engine warning light on and does LED indicate CODE 4?

NO

Intermittent failure. system is OK at this time (test drive may be necessary).  
Check for poor connections or loose wires at the distributor connector and C210 (round connector located at the right shock tower).

YES

Stop engine.

Disconnect the 8P connector from the TDC/CRANK/CYL sensor.

Measure resistance between C terminal and D terminal.

Is there 350-700  $\Omega$  ?

NO

Replace the distributor assembly (section 16).

YES

(To page 6-29)

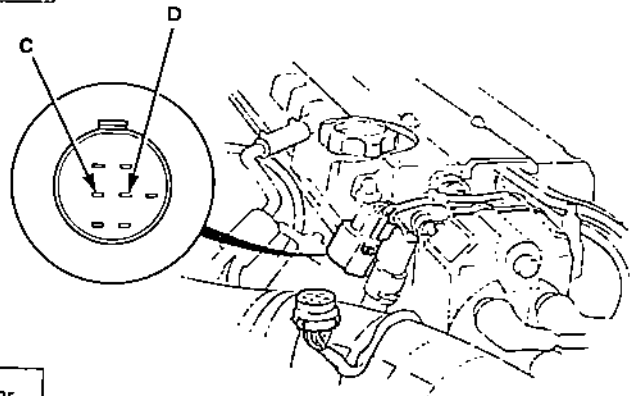



(From page 6-28)

Check for continuity to body ground on C terminal and D terminal individually.

Does continuity exist? YES → Replace the distributor assembly (section 16).

NO

Reconnect the connector.

Connect the PGM-FI test harness only to the main wire harness, not to the ECU (page 6-13).

Measure resistance between B10 terminal and B12 terminal.

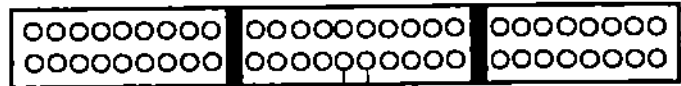

B10 B12  
350-700Ω ?

Is there 350-700Ω? NO → Repair open in ORN and/or WHT wires.

YES

Check for continuity to body ground on B10 terminal.

Does continuity exist? YES → Repair short in ORN wire between ECU (B10) and distributor connector.

NO

Substitute a known-good ECU and recheck. If symptom/indication goes away, replace the original ECU.

(cont'd)

# PGM-FI Control System

## Troubleshooting Flowchart — TDC/CRANK/CYL Sensors (cont'd)

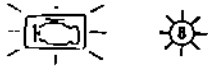

- Check Engine warning light has been reported on.  
- LED indicates CODE 8.

Turn the ignition switch OFF.

Remove HAZARD fuse in the main fuse box for 10 seconds to reset ECU.

Start engine.

Is Check Engine warning light on and does LED indicate CODE 8?

Intermittent failure, system is OK at this time (test drive may be necessary).  
Check for poor connections or loose wires at distributor connector and C210 (round connector located at the right shock tower).

Stop engine.

Disconnect the 8P connector from the TDC/CRANK/CYL sensor.

Measure resistance between A terminal and B terminal.

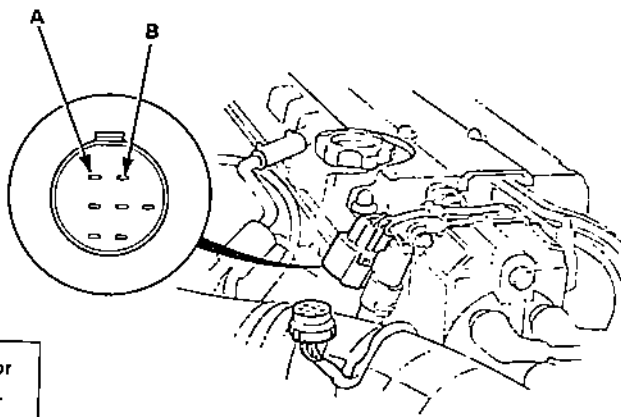

Is there 350-700 Ω?

Replace the distributor assembly (section 16).

Check for continuity to body ground on A terminal and B terminal individually.

Does continuity exist?

Replace the distributor assembly (section 16).

Reconnect the connector.

(To page 6-31)



(From page 6-30)

Connect the PGM-FI test harness only to the main wire harness, not to the ECU (page 6-13).

Measure resistance between C3 terminal and C4 terminal.

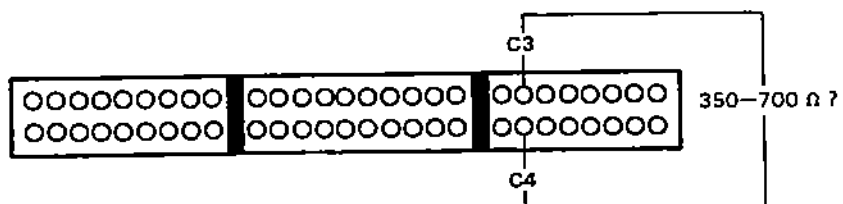

Is there 350-700  $\Omega$  ?

NO

Repair open in ORN/BLU and/or WHT/BLU wires.

YES

Check for continuity to body ground on C3 terminal.

Does continuity exist?

YES

Repair short in ORN/BLU wire between ECU (C3) and distributor connector.

NO

Substitute a known-good ECU and recheck. If symptom/indication goes away, replace the original ECU.

(cont'd)

# PGM-FI Control System

## Troubleshooting Flowchart — TDC/CRANK/CYL Sensors (cont'd)

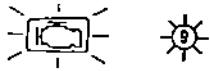

- Check Engine warning light has been reported on.  
- LED indicates CODE 9.

Turn the ignition switch OFF.

Remove HAZARD fuse in the main fuse box for 10 seconds to reset ECU.

Start engine.

Is Check Engine warning light on and does LED indicate CODE 9?

Intermittent failure, system is OK at this time (test drive may be necessary).  
Check for poor connection or loose wires at the distributor connector and C210 (round connector located at the right shock tower).

Stop engine.

Disconnect the 8P connector from the TDC/CRANK/CYL sensor.

Measure resistance between F terminal and G terminal.

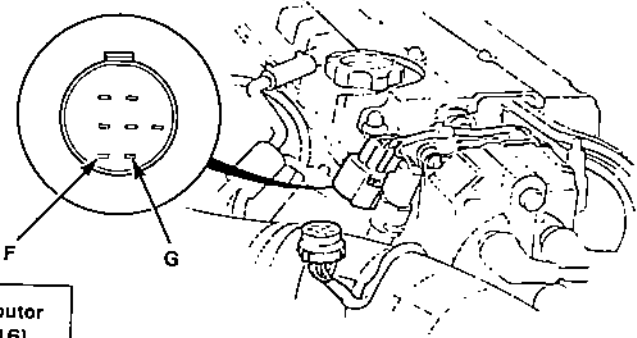

Is there 350-700 Ω ?

Replace the distributor assembly (section 16).

Check for continuity to body ground on F terminal and G terminal individually.

Does continuity exist ?

Replace the distributor assembly (section 16).

Reconnect the connector.

(To page 6-33)



(From page 6-32)

Connect the PGM-FI test harness only to the main wire harness, not to the ECU (page 6-13).

Measure resistance between C1 terminal and C2 terminal.

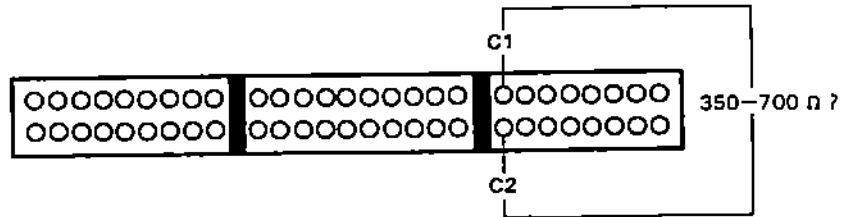

Is there 350-700 Ω ?

NO

Repair open in BLU/GRN and/or BLU/YEL wires.

YES

Check for continuity to body ground on C1 terminal.

Does continuity exist?

YES

Repair short in BLU/GRN wire between ECU (C1) and distributor connector.

NO

Substitute a known-good ECU and recheck. If symptom/indication goes away, replace the original ECU.