

PGM-FI Control System

Troubleshooting Flowchart — Ignition Output Signal



Self-diagnosis LED indicates code 15: A problem in the Ignition Output Signal circuit.

- Check Engine warning light is on.
- LED indicates CODE 15.

Turn the ignition switch OFF.

Remove HAZARD fuse in the main fuse box for 10 seconds to reset ECU.

Start engine.

Is Check Engine warning light on and does LED indicate CODE 15?

NO

Intermittent failure, system is OK at this time (test drive may be necessary).
Check for poor connections or loose wires at the distributor connector and C212 (square connector located at the right shock tower).

YES

Turn the ignition switch OFF.

Disconnect the 2P connector from the distributor

Turn the ignition switch ON.

Measure voltage between BLK / YEL (+) terminal and body ground.

Is there battery voltage?

NO

Repair open in BLK/YEL wire between the 2P connector and ignition switch.

YES

Turn the ignition switch OFF.

Reconnect the 2P connector

(To page 6-43)

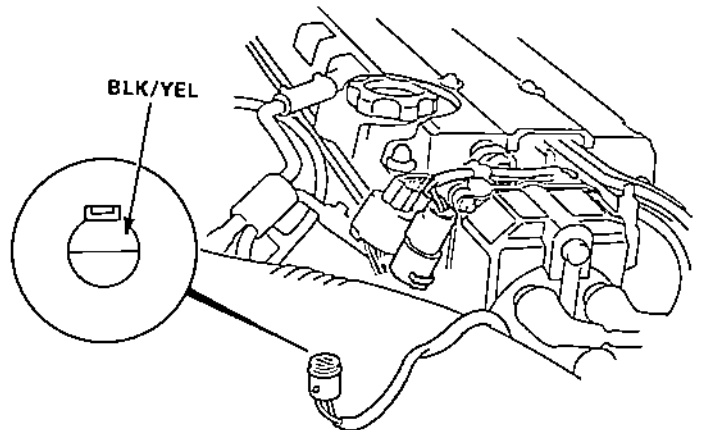



(From page 6-42)

Connect the PGM-FI test harness between the ECU and connector (page 6-13).

Turn the ignition switch ON.

Measure voltage individually between B15 (+), B17 (+) terminals and A18 (-) terminal.

Is there approx. 10 V?

NO

YES

Substitute a known-good ECU and recheck. If symptom/indication goes away, replace the original ECU.

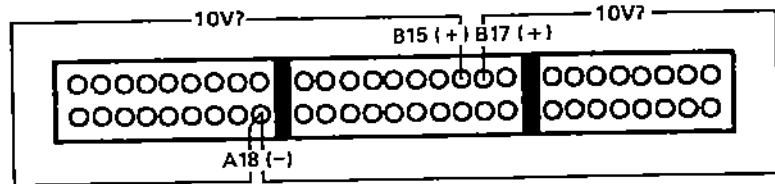

- Replace the igniter unit.
- Repair open or short WHT wires between distributor and ECU (B15 or B17).

NOTE: If the WHT wire was shorted, the ignitor may be damaged.