

Idle Control System

Fast Idle Valve

Inspection

NOTE: The fast idle valve is factory adjusted; it should not be disassembled.

1. Remove the intake air duct from the throttle body.
2. Start the engine and allow it to idle.
3. Put your finger over the lower port in throttle body and make sure that there is air flow with the engine cold (coolant temperature below 30°C, 86°F).

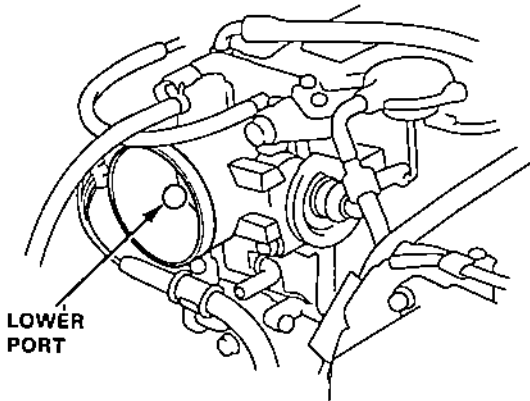

- If there is air flow, go to step 4.
- If not, replace the fast idle valve and retest.

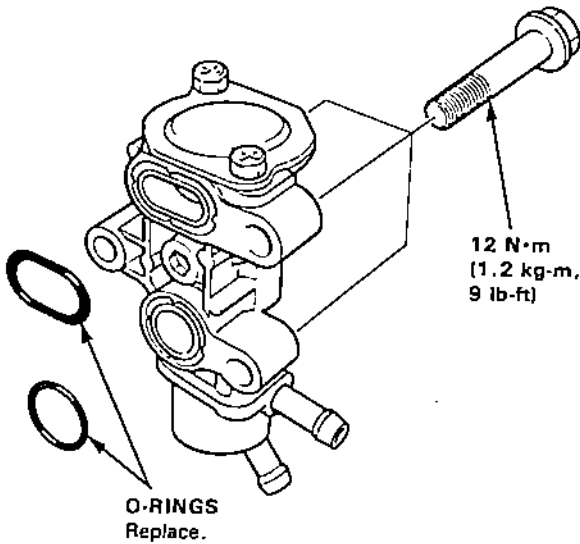

4. Warm up the engine (cooling fan comes on).
5. Check that there is no air flow at the lower port and no change in idle speed.
 - If the idle speed is lower with the port covered, replace the fast idle valve and retest.
 - If the idle speed remains the same, the fast idle valve is OK.