



Fuel Pressure

Relieving

WARNING

- Do not smoke while working on the fuel system. Keep open flames or sparks away from the work area.
- Be sure to relieve fuel pressure while the engine is off.

NOTE: Before disconnecting fuel pipes or hoses, release pressure from the system by loosening the 6 mm service bolt at top of the fuel filter.

1. Remove fuel filter cap.
2. Disconnect the battery negative cable from the battery negative terminal.
3. Use a box end wrench on the 6 mm service bolt at top of the fuel filter, while holding the special banjo bolt with another wrench.
4. Place a rag or shop towel over the 6 mm service bolt.
5. Slowly loosen the 6 mm service bolt one complete turn.

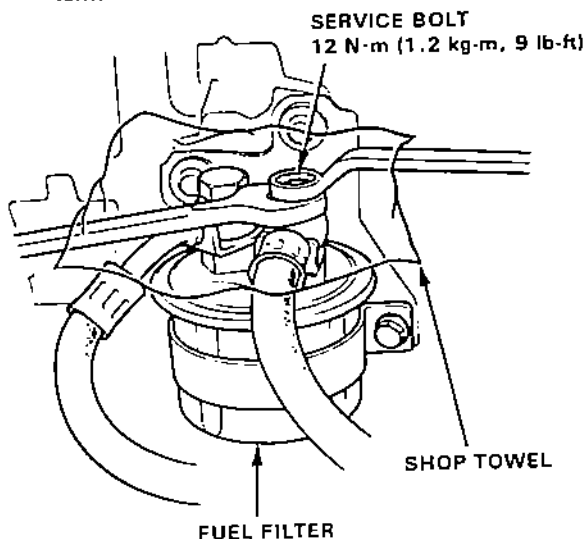

NOTE:

- A fuel pressure gauge can be attached at the 6 mm service bolt hole.
- Always replace the washer between the service bolt and the special banjo bolt, whenever the service bolt is loosened to relieve fuel pressure.
- Replace all washers whenever the bolts are removed to disassemble parts.

Inspection

1. Relieve fuel pressure.
2. Remove the service bolt on the top of the fuel filter while holding the banjo bolt with another wrench and attach the fuel pressure gauge.
3. Start the engine. Measure the fuel pressure with the engine idling and vacuum hose of the pressure regulator disconnected.

Pressure should be:
240–279 kPa (2.45–2.85 kg/cm², 35–41 psi)

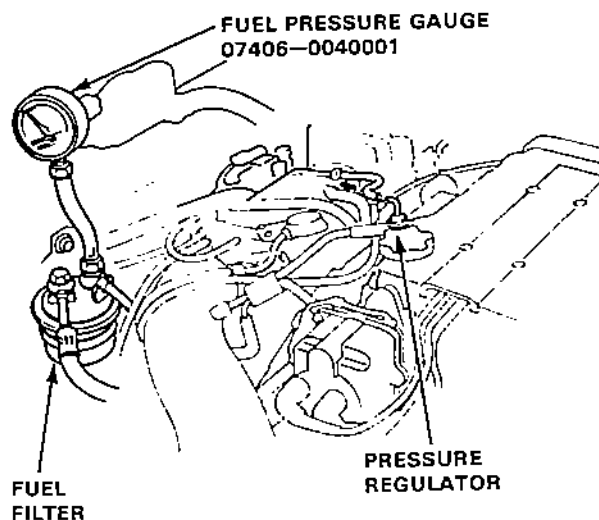

- If the fuel pressure is not as specified, first check the fuel pump (page 6-72), if the pump is OK, check the following:
 - If the pressure is higher than specified, inspect for:
 - Pinched or clogged fuel return hose or piping.
 - Faulty pressure regulator (page 6-68).
 - If the pressure is lower than specified, inspect for:
 - Clogged fuel filter.
 - Pressure regulator failure (page 6-68).
 - Leakage in the fuel line.