

# Brake Booster

## Test

### Leak Test

1. Install the Brake Power Kit (07504-6340100) as shown.
2. Start the engine, adjust the engine speed with the accelerator pedal so that the vacuum gauge readings show 300-500 mmHg (11.8-19.7 inHg), then stop the engine.
3. Read the vacuum gauge.

If the vacuum readings decreases 20 mmHg (0.8 inHg) or more after 30 seconds, check following parts for leaks.

- Check valve
- Vacuum hose
- Seals
- Master cylinder O-ring and cup
- Diaphragm

VACUUM JOINT TUBE A  
07510-6340300 or  
B 07510-6340400

VACUUM GAUGE  
07404-5790300

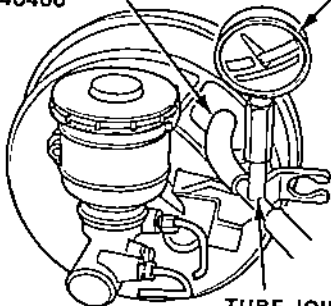

TUBE JOINT ADAPTOR  
07410-5790500

### Function Test

1. Install the vacuum gauge as same the leak test.
2. Connect the oil pressure gauges to the master cylinder using the attachments as shown.
3. Bleed air through the valves.

**CAUTION:** Avoid spilling brake fluid on painted, plastic or rubber parts as it may damage the finish.

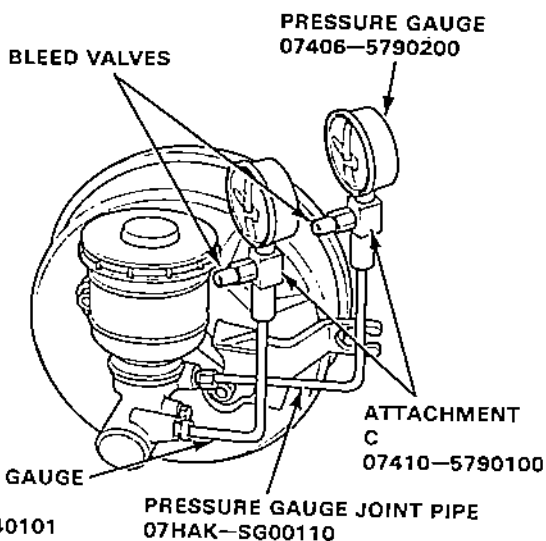

4. Start the engine.

5. Depress the brake pedal with a 200 N (20 kg, 44 lbs) of pressure. The following pressures should be observed at the pressure gauges in each vacuum.

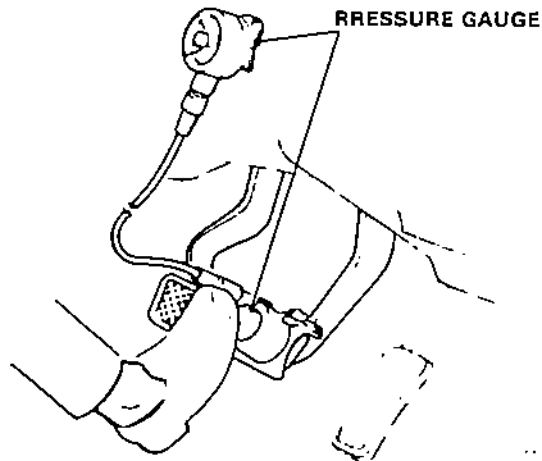

Vacuum mmHg	Line pressure kPa (kg/cm <sup>2</sup> , psi)
0	900 (10.1, 143) min.
300	4,560 (45.5, 661) min.
500	6,933 (70.7, 1,005) min.

6. Inspect the master cylinder pistons and cups in the readings do not fall within the limits shown above.

### Check Valve Test

1. Remove the check valve, blow on one end of the hose and then the other; if you can blow through the booster end, but not through the manifold end, the check valve is OK.

