



## CAUTION:

1. Always disconnect the negative cable from the battery whenever replacing air conditioner parts.
2. Keep moisture and dust out of the system. When disconnecting any lines, plug or cap the fittings immediately; don't remove the caps or plugs until just before the lines are reconnected.
3. Before connecting any hose or line, apply a few drops of refrigerant oil to the seat of the O-ring or flare nut.
4. When tightening or loosening a fitting, use a second wrench to support the matching fitting.
5. When discharging the system, don't let refrigerant escape too fast; it will draw the compressor oil out of the system.
6. Add refrigerant oil after replacing the following parts:
 

Condenser .....	10 cc (1/3 fl oz)
Evaporator .....	30 cc (1 fl oz)
Line or hose .....	10 cc (1/3 fl oz)
Receiver .....	10 cc (1/3 fl oz)
Compressor .....	On compressor replacement, subtract the volume of oil drained from the removed compressor from 80 cc (2 2/3 fl oz), and drain the calculated volume of oil from the new compressor: 80 cc (2 2/3 fl oz) — Volume of removed compressor = Draining volume.

## 7. Torque specifications

① Suction hose evaporator side .....	24 N·m (2.4 kg-m, 17 lb-ft)
and compressor side	
② Receiver pipe C evaporator side .....	17 N·m (1.7 kg-m, 12 lb-ft)
③ Receiver pipe C to Receiver pipe B .....	17 N·m (1.7 kg-m, 12 lb-ft)
④ Receiver pipe B to Receiver pipe A .....	17 N·m (1.7 kg-m, 12 lb-ft)
⑤ Condenser pipe to Condenser .....	10 N·m (1.0 kg-m, 7 lb-ft)
⑥ Discharge hose condenser side .....	24 N·m (2.4 kg-m, 17 lb-ft)
and compressor side	
⑦ Receiver tank .....	10 N·m (1.0 kg-m, 7 lb-ft)
⑧ Compressor bracket mounting bolts (10 x 45) ...	48 N·m (4.8 kg-m, 35 lb-ft)
⑨ Compressor bracket mounting bolts (10 x 55) ...	48 N·m (4.8 kg-m, 35 lb-ft)
⑩ Compressor mounting bolts .....	25 N·m (2.5 kg-m, 18 lb-ft)
⑪ Idle pulley stay bolt .....	48 N·m (4.8 kg-m, 35 lb-ft)

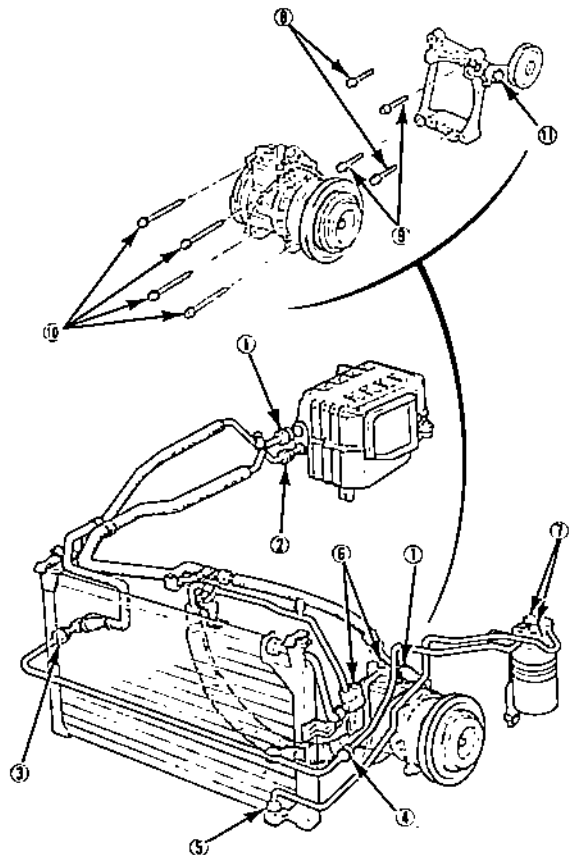

## WARNING

When handling refrigerant (R-12):

- Always wear eye protection.
- Do not let refrigerant get on your skin or in your eyes. If it does:
  - Do not rub your eyes or skin.
  - Splash large quantities of cool water in your eyes or on your skin.
  - Rush to a physician or hospital for immediate treatment. Do not attempt to treat it yourself.
- Keep refrigerant containers (cans of R-12) stored below 40°C (100°F).
- Do not handle or discharge refrigerant in an enclosed area near an open flame; it may ignite and produce a poisonous gas.
- The ozone is a fragile layer surrounding the earth which acts as a shield against the sun's ultraviolet radiation. Chlorine from chemicals called Chlorofluorocarbons (CFCs) destroy the ozone in the stratosphere. Automotive air conditioning systems currently use Chlorofluorocarbons as the refrigerant. Auto air conditioning service equipment has been developed to minimize the release of CFCs to the atmosphere. All service procedures should be performed using this equipment and the manufactures instructions.