

Fuel Gauge

Sending Unit Test

▲WARNING Do not smoke while working on fuel system. Keep open flame away from work area.

1. Remove the rear seat, then remove the maintenance access cover.
2. Check that the ignition switch OFF, then disconnect the 3-P connector from the fuel gauge sending unit.
3. Remove the fuel gauge sending unit.

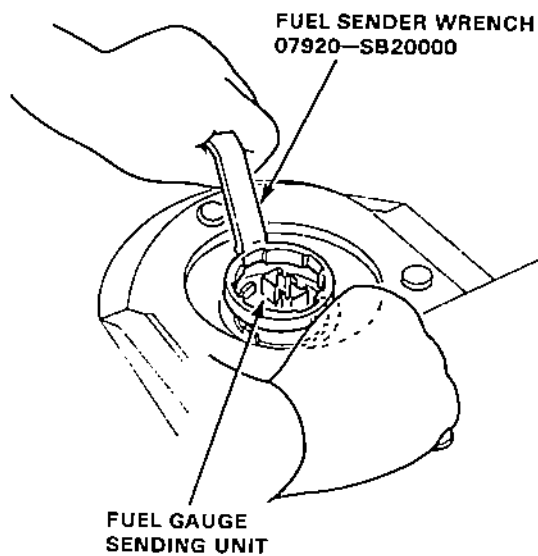

4. Measure the resistance between the A and B terminals at E (EMPTY), 1/2 (HALF FULL) and F (FULL) by moving the float.

Float Position	E	1/2	F
Resistance (Ω)	105-109	27.5-37.5	2-5

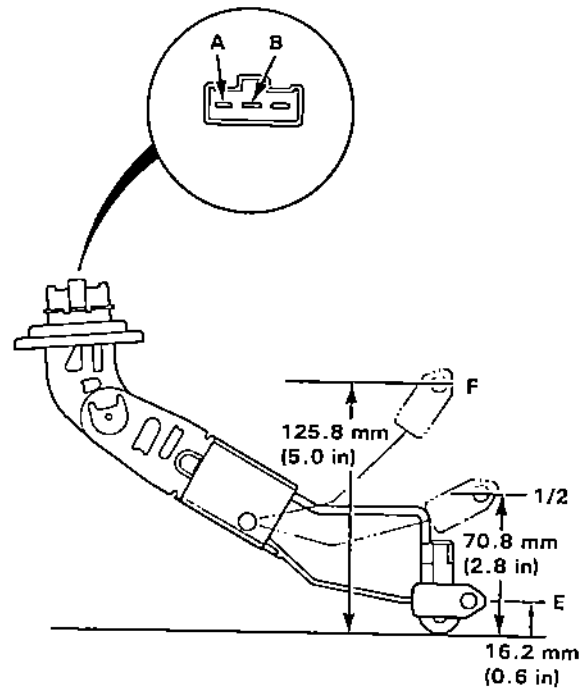

5. If unable to obtain the above readings, replace the fuel gauge sending unit.